



**Roberto  
Sánchez**

---

PORTFOLIO

ROBERTO P. SANCHEZ SEGURA

THE RPS BOOK - PORTFOLIO



**EDITOR / AUTHOR:**  
**ROBERTO P. SANCHEZ SEGURA**

**THE RPS BOOK - PORTFOLIO**

robertopablo.sanchez@gmail.com

SEGUNDA EDICION / SECOND EDITION

NO. DE PARTE / PN: RPS001-2012

IMPRESO EN USA

PRINTED IN USA

Queda rigurosamente prohibido sin autorización escrita del editor bajo las sanciones establecidas en las leyes, la reproducción parcial o total de esta obra por cualquier medio o procedimiento, comprendidos la reprografía y el tratamiento informático y la distribución de ejemplares de ella, mediante alquiler o préstamo público.

Its expressly prohibited from reproducing, distributing, transforming, publicly communicating, making available to others, extracting, re-using, forwarding or exploiting, by any means or procedure, the content of this publication and its components, except where permitted by law or with the express written authorisation of the author.



# Roberto Sánchez

---

PORTFOLIO

**Marketing + Design**

Design to create a  
total brand presence



“Design with passion  
under a global thinking.”

# Perspective

## COMMUNICATION ISSUES

The perspective role of a brand director or marketing manager, an important goal is to create an efficient communication to its market in order to promote their products and services, as well as create brand awareness and increase revenues and presence. This task is not easy to achieve; new methods and media are increasing such as handheld, laptop, cell phones, smart phones, I-pad and so on, which requires new techniques and knowledge to create and transmit successful messages and promotions to the market, so this industry is becoming more exciting and more complex.

**The complexity of a message** will depend on the market target audience, its habits and previous brand experience, as well as company sales forecast and marketing strategy.

Working closely with other company departments such as Publicity / Marketing / Sales and through a market research - interviews and market analysis, will help us to make a clear understanding of how to direct the company communication. The shared results from specialist

of different company departments mentioned before will result into a well oriented marketing material support. A well structured information included on this marketing material will create a more effective messages and understanding of the final user, which is associated with a good quality product with a high added value.

The consumer is well informed, due to the Internet browsers and specialized websites, so, each product that we create must have all the effective elements to be competitive in a global world. That is why the artwork, concept art, copy and brand, plays an important role to convince consumer in its buying decision, but also to feel identified with the brand.

**The objective of the marketing material** is not only to present a brand, its information and concept. Must promote the benefits and characteristics of a product or a service. Therefore the designer must know everything related to the product or service in order to create a specific profile in his mind and transform this into colours, shapes, logos, he also must include

the motto and promise that the brand will be remembered in the future.

We design for the eyes, one of the most important senses of the human body; hence society identifies many different types of elements and symbols without words. They see how the quality of a product is, or how they "feel" about a brand. We not only communicate shapes, colours, copy, photos, we communicate feelings, emotions and knowledge.

**The focus that I presenting** in my work is based on a local approach to the problem but with a global perspective solution. The brands are not limited to regional boundaries.

This portfolio presents just one part of all the work that I have created for 16 years, and everyday I confirm that design is my passion and everything can be perfected, always.

**I hope you enjoy it.**

*Peachtree City, GA, 2018*

*Yours.*

### **Roberto P. Sanchez**

MBA (Hons) Master of Business Administration  
BFA. (Hons) Graphic Communication Designer  
Diploma. Strategic Marketing Communication

Any inquiries, please refer to:  
robertopablo.sanchez@gmail.com



## Important Notes:

The following portfolio shows part of the professional artwork for over the past 16 year of nonstop activity. Each project has an ID number that carries out its description, project name and technical information.

You will find in several sections a display of projects developed for the German company HELLA KGaA and its sales companies in United States of America, Mexico, Singapore and South Africa for the automotive aftermarket sector. As marketing and communications manager in HELLA Mexico, this artworks belonged to my strategic marketing planning for over the past years.

Please notice that you will find further information and detailed explanations on **THE RPS PORTFOLIO - THE HELLA WORKS**. Is important to mention that due this document content will pass or distributed due to copyrights and confidentiality.

THE RPS PORTFOLIO- THE HELLA WORKS is divided in four parts. Each part corresponds to one annual report per Fiscal Year (May-June ) according to the German calendar. It describes on detail the marketing activities that I developed since 2005. This marketing activities report was submitted to the HELLA Headquarters in Germany.

**Reference:**  
CMYK = Cyan, Magenta, Yellow, Black or indicated spot colours.

Project photo



Project ID in a consecutive numbering

048

Company / Country

**MIND STORM Studios - South Africa**  
File folder design. CMYK Printed.  
220 x 280 x 5 cm. Artwork

*Project description - Technical specifications.  
Size. Additional comments.*

Colour bar refers to each section mentioned on the Index

## AWARDS

As Marketing Manager for Mexico, South Africa and the USA, the entry annual reports (mentioned above), were awarded by **HELLA KGaA with the First Place in the Marketing Activities category, for 9 times (4 in a row) from 35 sales companies around the world in the Sales Company of the Year competition for 2005-2018 period.**

About HELLA:

HELLA KGaA with headquarters in Lippstadt, Germany is a world leader in the automotive industry on the Electrics, electronics and lighting producer for the OE car producers such as VW, Mercedes Benz, Audi, BMW, Nissan, Ford, etc, with 25,000 employees around the world and presence in more than 75 countries world-wide.



# Key Elements

## Mind setup - Skills



The marketing strategy thinking includes a more complex communications plan, plus analyse the brand awareness impact, create useful databases as well as optimize the marketing budget of a company or to offer a reliable solution to customers based on a cost benefit and a good ROI.

Also the knowledge of new tools on this digital 2.0 and 3.0 revolution as Blogs, Post and Social Media as well as audio, video and post-production in 2D and 3D environments.

Here you will find the strategic tools as my mind set in order to archive a successful communications objective in order to generate more opportunities for a company, the motto and promise that the brand will be remembered in the future.









## INDEX:

Section:

Page:

### Corporate Identity

Logotypes, corporate manuals, icons, stores signing and stationary.

10

### Printed Literature

Leaflets, flyers, catalogs, brochures and postcards.

26

### Packaging

Boxes, plastic packaging labels and limited edition packaging.

50

### Web Sites

Corporate websites, banners and e-newsletter.

66

### Video and Interactive Media

Interactive content, electronic presentations and corporate videos.

74

### Exhibitions / POS

Point of purchase materials, stands design and furniture.

96

### Photography

Indoors / outdoors photography.

112

### Projects References

156

The coloured bars in the content list match the quick-finder at the side helping you find the desired section easily.

R

How to avoid  
remember never give up  
dreaming and thinking  
follow your instincts  
Does it make sense  
want to create a better world  
The best ideas come when  
Are you creative mind working as usual  
Creativity not  
Design Creation  
Genius innovation  
Trust  
Freedom for  
Ideas  
Faith  
Answers not  
direction  
Artistic  
Passion  
Love  
Intellectual  
Trust  
Innovate, moving forward  
battle its not over yet  
what it, its really important  
to the knowledge is the

Don't be afraid to innovate

# Corporate Identity

Logotypes, corporate manuals, icons,  
stores signing and stationary.

## BUILDING A BRAND EXPERIENCE

# 001

## MAGIKA Studios - United States

Logotype, business stationery and corporate design

The MAGIKA STUDIOS logo was designed to be unique and easily recognizable, and to communicate its personality on many levels. Its fun, exciting and energetic.

Imagery is also important part of the MAGIKA STUDIOS brand identity. In addition to developing a traditional Pantone palette or primary and accent colors, I created a vivid image library consisting is "hand painted" images and brush stroke backgrounds.

Each of these categories is color-coded for application. The MAGIKA green color fosters identification of the business group of the company.



### DESIGN SYSTEM APPLICATION EXAMPLES

When using the MAGIKA STUDIOS design system and placing the logo within a project, but Not inside of the primary or secondary bands, please allow for at least the "X" mark's height as minimum clear space. Additionally, position the logo in a corner of the layout when possible.

**General logo clear space requirement:**  
A minimum of clear space equal to the height of the "X" must be maintained.

MAGIKA\_Logo\_001 - Brand, Stationery, 1.01 Jul 2015  
MAGIKA Corporation



DESIGN SYSTEM  
ADVERTISEMENTS

Advertisement reach the target group directly and are therefore very important for MAGIKA communications. They often represent the first opportunity to establish contact with a particular group of people. In view of this, observance of the layout rules is particularly important.

The advertisement must always be in color as the green MAGIKA label with two-dimensional logo is an integral part of the corporate image. Black/white adverts are not a component of the MAGIKA Corporate Design.

The layout of adverts is governed by the basic rules already covered in the chapters entitled Basic Elements and Design Principle. These chapters should, amongst other things, serve as a guide as to how the page layout can be calculated for different advert formats.



# 002

**MDANGE Group - South Africa**  
 Logotype and business stationery design

MDANGE is a transportation and logistics company in the Uitenhage region in South Africa. The logo expresses constant movement, flexibility and partnership towards its customers.



# 003

**TCW Studios**  
 Business stationery design.

The TCW Studios project began by creating the logo, including a new stationery package also promotional material such as notebooks, pens and pencils.



85 x 55 mm business card  
 A4 stationery sheet

004

TCW Studios  
Logo design.

The new logo for TCW Studios communicates a "formal and academic style" for a communications and video post-production company.



# TCW Studios

005

TCW Studios  
Corporate stationery  
and brochures.



# 006

The Creative Workshop  
Sales campaign material.

Customers postcard  
4 x 1 inks printed offset



 <b>The Creative Workshop</b> ™ <span style="float: right;">Creating a World of Ideas™</span>				
The Creative Workshop es la solución oportuna a los problemas de publicidad y promoción de pequeñas, medianas y grandes empresas mexicanas e internacionales. Nuestra filosofía gira en torno a de la máxima calidad y en la entera satisfacción de nuestros clientes utilizando al máximo nuestra creatividad haciendo uso de la última en tecnología. Entre sus nuestros servicios y productos que le ofrecemos:				
<b>TCW Global Branding</b> Campañas Publicitarias Mercadotecnia Directa Telemarketing Relaciones Públicas Correo Directo Diseño de Imagen Corporativa Diseño de Marcas Medios Masivos Cine, Radio, Televisión Medios Impresos Publicidad exterior Rotulación de Vehículos Museografía y exposiciones Señalización Interna de Empresas Apoyo de medios electrónicos on line y publicidad electrónica directa Diseño Editorial, Reportes Anuales Manuales, Comunicación Interna	<b>TCW Interactive</b> Publicidad Digital Desarrollo de Sistemas Interactivos Presentaciones Multimedia Presentaciones Profesionales Power Point™ Animación en Tercera Dimensión Digitalización de Video Edición de video no lineal, compoite para video y Efectos Visuales Edición de Contenido para DVD Recorridos Virtuales 3D Desarrollo de Sitios Web Hosting y Registro de Dominios Pùbmail Wikioos Virtuales	<b>TCW Design Solutions</b> Retoque Fotográfico Digital Vectorización de Logotipos e Ilustraciones Escaneo de Transparencia, Negativos y Cuerpo Opacos Ilustración Tradicional y digital Fotografía profesional de exteriores y tema productos Impresión digital de Gran Formato Formación de revistas y periódicos	<b>TCW Packaging Division</b> Diseño Gráfico de Envases Líneas de Productos: Gift-Wrap Packaging Solutions Special Packaging Solutions Servicios técnicos Investigación y desarrollo Diseño de empaques Diseño estructural Consultoría de emvasado	<b>TCW Products</b> CD-ROM, Mini Disc y Business Card Ofrecemos los servicios de: Replicado de CD y DVD Duplicado de CD y DVD Empaques para CD, Mini Disc y Business Cards Accesorios Impresión y etiquetado de CD Artículos Promocionales Material para Punto de Venta Carpas Promo-Stands Exhibidores
<small>                     Designed by: R. Pablo Sánchez Segura.                      © The Creative Workshop es una marca registrada, el logo y Creating a World of Ideas son marcas registradas de The Creative Workshop.                      © The Creative Workshop 2003. Todos los derechos reservados.                      Todas las marcas mencionadas son propiedad de sus respectivos propietarios.                 </small>				
<small>                     Si el interesado desea contactar al diseño, tener o saber al respecto del mismo:                      Corporative Office: Blvd. Popocatepetl No. 60, Los Peñales, Tlalnequarrilla, Edo. de México, C.P. 54040, México.                      E-Mail: sales@tcw.com.mx                      www.tcw.com.mx                      Web-Site: (55) 9113-3219                      Telephone: (55) 5379-0220                      Fax:                 </small>				



Art concept for campaign





# 007

**The Creative Workshop**  
Corporate material - storage



3.5 diskette and mini disc storage units for internal use.



ZIP and mini disc cases including the corporatedesign manual and documents.



CD sleeve include the corporate design manual.

# 008

**The Creative Workshop**  
Concept design for internal documents

# 009

**The Creative Workshop**  
Sleeve for interactive CD.



CLAUDIVA LEDESMA  
photography



- | 010 Claudiva Ledesma  
Logo design and business stationery
- | 011 Max Cafe Group  
Logo design
- | 012 Alterra - Music Store  
Logo design

- | 013 Napolis - Chocolate brand  
Logo design
- | 014 Mantecadas Pierre's  
Logo design
- | 015 Arts Magazine  
Logo design

# 016

**Skoleni - Digital Art School**  
Logo design and business stationery

The corporate identity required a modern and dynamic stylish logo for the nowadays evolving technology. The logo has a 3D look aspect. Web-site, interactive media, course material, business stationery was created to promote this business with great response from the audience.



# SKOLENI



With branches all around South Africa, SKOLENI emerges as a digital training business since 2013. They provide design, animation and digital video training classes.



# 017

## Sweet Celeste

Logo design, business stationery and corporate design manual

The SWEET CELESTE® is a specialized bakery. Its main product for the commercial business is macaroons. A macaroon is a type of small circular cake, typically made from ground almonds, coconut, and/or other nuts or even potato, with sugar, egg white, and sometimes flavorings, food coloring, glaze cherries, jam and/or a chocolate coating



The logo and its corporate identity guidelines has a hand-made look, with pastels colors to evoke the feminine side of the product with the motto "Love in every bite".

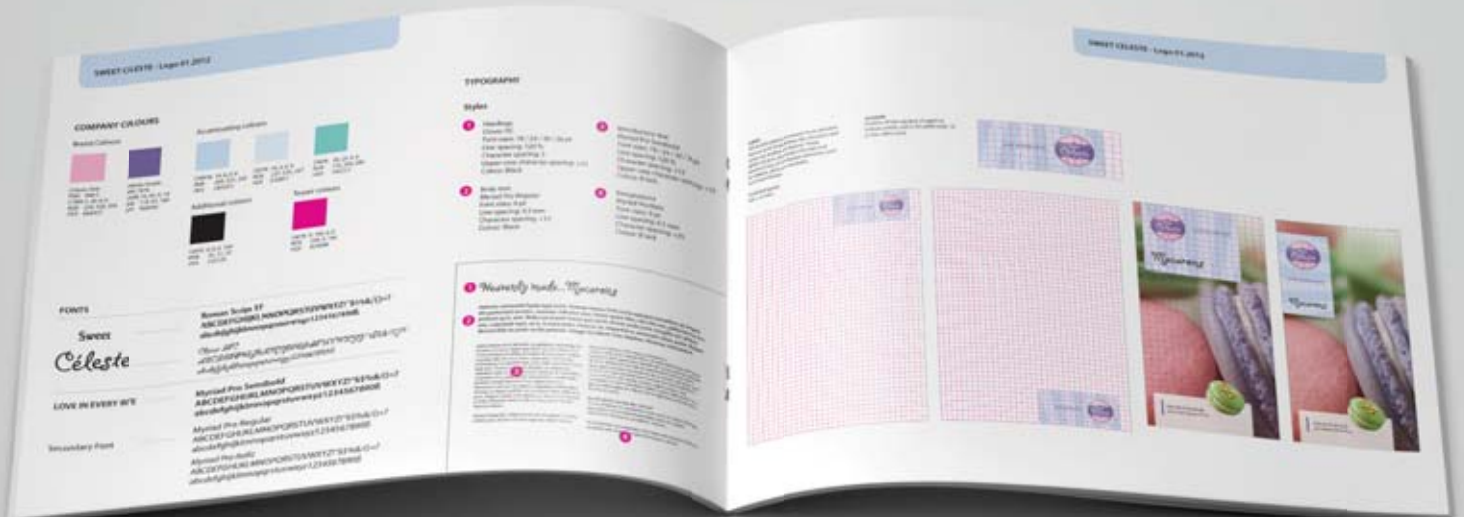

018

**Unipack Group**

Logo design, business stationery and corporate design manual

The Packaging Service company is dedicated in develop fast food packaging, box containers, gift wrap and design services. They are oriented in provide services to small to mid-size companies. Therefore the look of the logo required to be more serious, clean and corporate.

A corporate identity book, catalogs and responsive website was created to reinforce their presence in the Mexican market.



# Unipack Group



# 019

**La Patisserie Francaise**  
Logo design and  
business stationery



# 020

**Body Care Center**  
Logo design and business stationery

The soft colors & design tone give a corporate zen look to the Body Care Center company.



# 021

**Giftwrap - Packaging Services**  
 CD package for customers including brochures and technical information.



# 022

**JJHF Ingeniería y Asociados**  
 Logo design corporate identity manual, CD and business stationery.



## INGENIERIA Y ASOCIADOS



## 023

**ENDIT - Escuela Nacional de Directores Técnicos**  
(National School of Trainer - Soccer)  
Logo and stationery business



The ENDIT School of Football Managers, provides training courses to coaches, the school is recognized by many Mexican National Associations of Football. Their courses are offered to small and selected groups.

The corporate design required a formal but dynamic style to invite, provoke and incite a new generation of coaches and enthusiast to direct football teams. A website was also create to promote their services. The interactive presentation snapshots (shown below) is part of training course to display the tactics and strategy in the game.





024

La Duela TV  
Logo design (Basketball TV Show)



025

Taconmaiz  
Logo design - Traditional mexican restaurant





# Printed Literature

Leaflets, flyers, catalogues, brochures and postcards.

Printed Literature



IDEAS MADE  
PRINTED

# 026

## The Creative Workshop

### Sales Tool Kit

Complete editorial creation from package design, graphic design, photos, etc. 40 pages. Full colour. Hard cover



**Servicios** 

**Servicios de Impresión**

15

El diseño con vistas a imprimirse prepara en sus documentos la información, identidad gráfica y fotografías, se provee el sistema de impresión, el sustrato de impresión (papel) y los acabados finales.

Para ventas, marketing y folletos corporativos, revistas institucionales y de empresas, reportes informativos, con fines promocionales.

Imprimimos en un sin número de aplicaciones gráficas tales como volantes, revistas, flyers, folletos, catálogos, trípticos, dípticos, invitaciones, libros, etc. en sistemas Offset, impresión digital y serigrafía, contamos también con acabados como barniz, barniz a registro, barniz UV, plastificado, engrapado doble y foliado.



**NOTA:** Los servicios de acabados finales están disponibles solo si se combinan o agregan al servicio de impresión.

**Servicios** 

**Diseño Gráfico de Envases**

13

El diseño de envases es la aplicación de la marca al extremo. El diseño de arte aplicado en los envases, es la permea y credibilidad del producto. También se representan sus valores y encanto a través de la investigación metodológica empleada a los consumidores para saber sus preferencias. En el diseño de envases se provee la forma del envase, colores a emplear, modo de impresión, pero además proveemos la fabricación y marcado del producto.

El proceso de diseño de envases se considera:

- Envases anteriormente fabricados.
- Investigación de mercado.
- Posicionamiento.
- Creación.
- Identidad de la marca.
- Extensión de identidad.
- Fotografía.
- Desarrollo de muestras gráficas.
- Desarrollo del arte para impresión.
- Arquitectura de la identidad (fidelidad y unidad en el paquete).
- Supervisión del proceso de implementación.



**Servicios** 

**Publicidad exterior**

11

Diseñamos e imprimimos en gran formato sobre lona, vinilona, lona translúcida, vinyl de corte a vinyl adherido autocadable con resolución de impresión de 360 a 900 dpi, para anuncios espectaculares, cajas de luz, paneles, tarjetas para punto de venta, exhibidores, stand y material P.O.P. (Point of purchase).



**Diseño editorial** 

El diseño editorial establece el tono y expresa la personalidad del contenido, así como de la empresa que se refleja. En los composiciones editoriales se toma en cuenta tanto el contenido visual como la legibilidad de los textos. Desarrollamos proyectos editoriales tales como: Diseño de libros, folletos, dípticos, trípticos, revistas, catálogos, magazines, postales, tarjetas, facturas, guías, informes anuales, manuales de operación, manuales corporativos, volantes, invitaciones, menús para restaurantes, mapas, etc.



Por favor, llámenos al 0212-2611111

# 027

## The Creative Workshop

Brochure. Corporate overview. 16 pages.  
Printed CMYK + 1 Spot colour.



Complete editorial creation from artwork to design, graphic design, photos and illustrations.

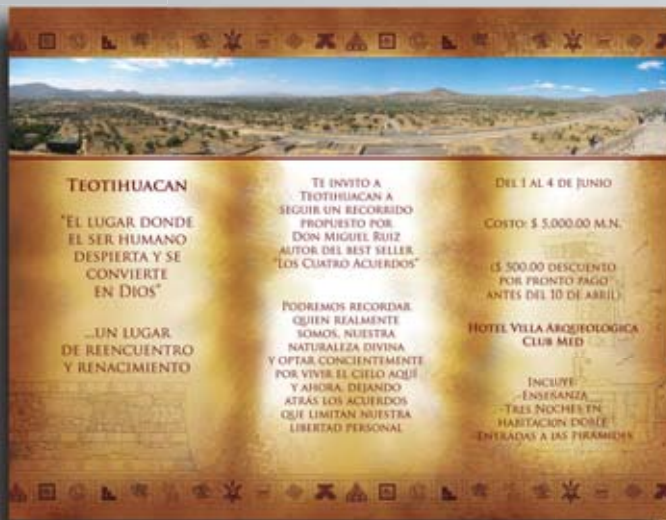

028

Mr. Günther Willenbrock  
Teotihuacan Leaflet  
CMYK Printed. Paper: 150 g

# 029

**BERU - Mexico**

Brochure - Wiper blades catalogue

Graphic design + Photos.

CMYK Printed. Paper: 150 g. 8 pages.



Printed Literature



# 030

Skoleni - Digital School  
 Postcard commercial  
 CMYK Printed. Paper: 10 pts.  
 Sulphated + UV coated



# 031

Universidad Autonoma Metropolitana  
 New Mexican Photographers  
 2 spot colour printed. Paper: 150 g

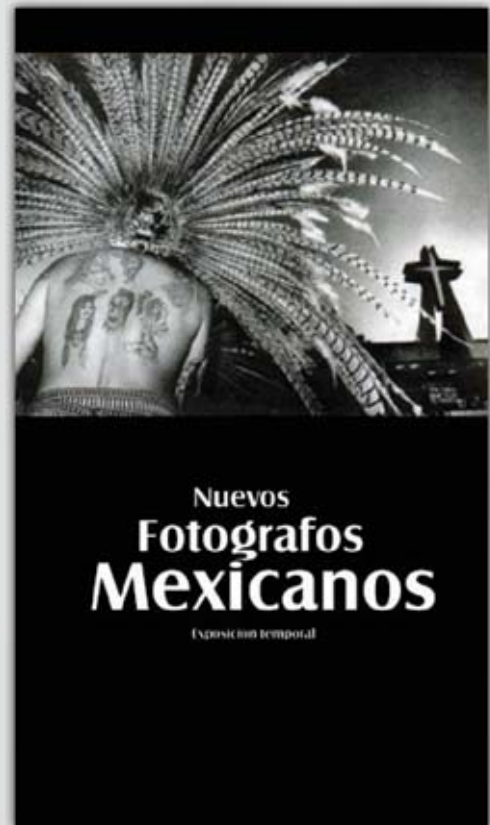



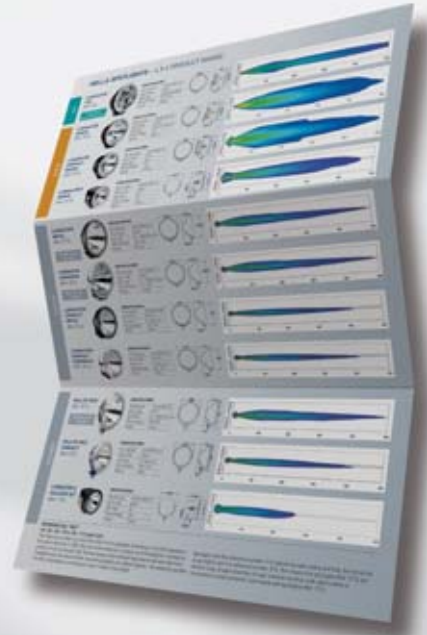

### 032

HELLA Automotive South Africa  
 Leaflet design  
 CMYK Printed. Paper: 10 pts.  
 Sulfated + UV coated



### 033

HELLA Automotive South Africa  
 High Performance Bulbs - Poster design  
 CMYK Printed. Paper: 10 pts.  
 Sulfated + UV coated

# 034

**Giftwrap - Packaging Services**  
 Catalogue - CMYK Printed. Paper: 150 g  
 Artwork + photos. 12 pages.



# 035

**Giftwrap - Packaging Services**  
 Catalogue - CMYK Printed. Paper: 150 g  
 Artwork + photos. 12 pages.

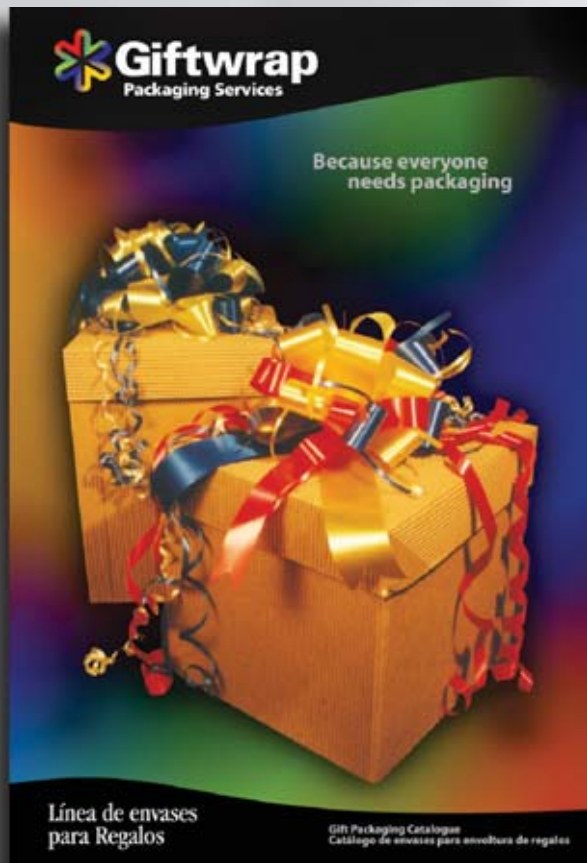

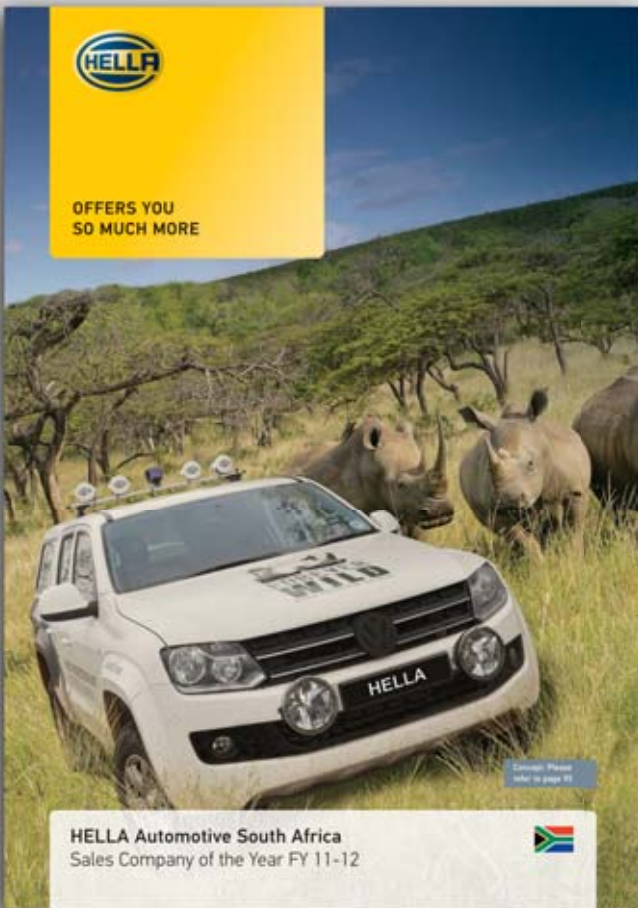

# 036

**HELLA Automotive South Africa**  
 Catalogue - CMYK Printed. Paper: 150 g  
 Artwork + photos. 60 pages.

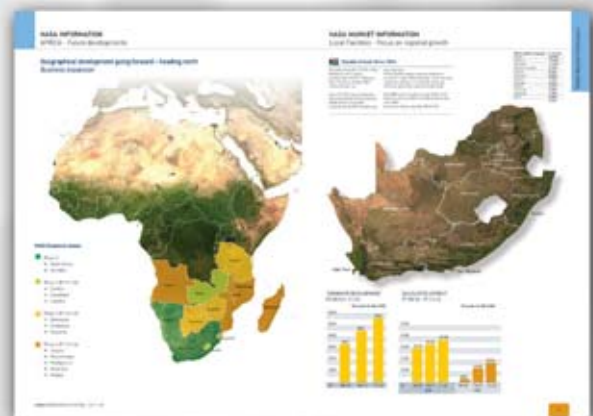

# 037

**PCE - Publicidad Corporativa Empresarial**  
Catalogue - CMYK Printed. Paper: 150 g  
Artwork + photos. 6 pages.

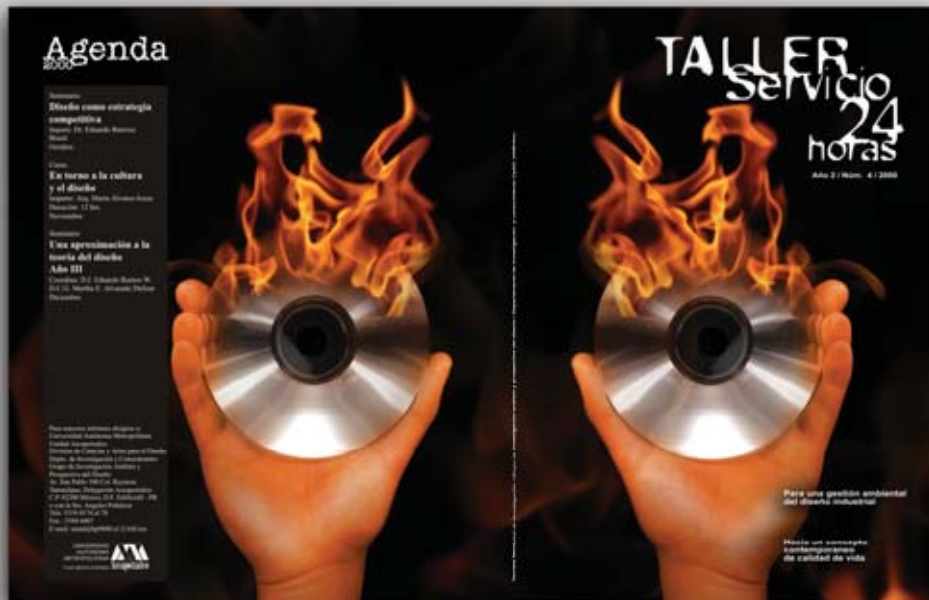

# 038

**Universidad Autonoma Metropolitana**  
**Taller 24 Horas**  
Magazine - CMYK Printed. Paper: 150 g  
Artwork + photos. 56 pages.

039

HELLA Automotive Sales, Inc.  
Poster - CMYK Printed. Paper: 150 g  
Artwork + photos.



# SIMPLY BRILLIANT

LED Auxiliary Lighting



HELLA, Inc.  
201 Kelly Drive  
Peachtree City, GA, 30269  
Tel.: +1 (677) 226-3552  
Fax: +1 (770) 631-7574  
[www.hella.com/americas](http://www.hella.com/americas)

Technology with Vision





040

Giftwrap - Packaging Services  
Newsletter design - CMYK Printed.  
Artwork + Copy



041

SKOLENI - Digital School  
Newsletter design - CMYK Printed.  
Artwork + Copy

042

SKOLENI - Digital School  
File folder design - CMYK Printed.  
Artwork + Copy

Eventos Especiales

# Hella Safety Tour ///

Te invita a la conferencia:

## Seguridad y Tecnología en Iluminación

Que se efectuará en el:  
**Auditorio de la UVM - Campus Lomas Verdes.**  
 12 de mayo del 2008 de: 18:30 a 21:00 hrs.

**¡No Faltes!**

Exhibición de productos Hella



Columnas, faros, focos y luces auxiliares, entre otros accesorios.



Drive Safety

Conoce toda la línea de accesorios Hella.

Visita:  
[www.hellamex.com](http://www.hellamex.com)



Ideas para el automóvil del futuro

043

HELLA - Mexico Safety Tour  
 Poster - CMYK Printed.  
 Paper: 250 g Artwork + photos.

Official Store

# Hella Shop

[www.hella-shop.com.mx](http://www.hella-shop.com.mx)

Todos los días a partir de las 10:00 AM  
 Contaremos con los servicios de:

- Nivelación de Faros
- Diagnóstico de Motor con Scanner
- Cambio de Focos y Plumas Limpiaparabrisas Hella
- Cambio de Bujías y Cables Beru

**¡Gratis!**  
 en todas sus compras



044

HELLA - Mexico. Hella Shop  
 Poster - CMYK Printed.  
 Paper: 250 g Artwork + photos.

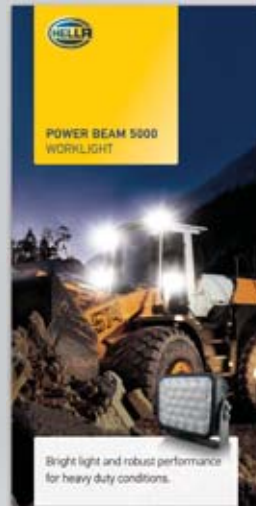
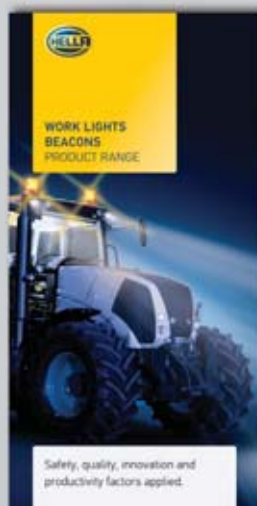

# 045 - 053

HELLA Automotive South Africa  
July 2011 - May 2012  
Catalogues and Leaflets  
CMYK Printed. Paper: 200 g  
Artwork + Copy



### LIGHTING THE FUTURE

**HIGH PERFORMANCE AUTOMOTIVE HALOGEN BULBS**

HELLA is a specialist manufacturer of halogen and LED lighting products. Our products are designed to meet the needs of the automotive industry, providing superior performance, reliability and safety. We have a long history of innovation and are committed to providing the highest quality products to our customers.

HELLA is a specialist manufacturer of halogen and LED lighting products. Our products are designed to meet the needs of the automotive industry, providing superior performance, reliability and safety. We have a long history of innovation and are committed to providing the highest quality products to our customers.

HELLA is a specialist manufacturer of halogen and LED lighting products. Our products are designed to meet the needs of the automotive industry, providing superior performance, reliability and safety. We have a long history of innovation and are committed to providing the highest quality products to our customers.

HELLA is a specialist manufacturer of halogen and LED lighting products. Our products are designed to meet the needs of the automotive industry, providing superior performance, reliability and safety. We have a long history of innovation and are committed to providing the highest quality products to our customers.

### LIGHT UP YOUR SALES!

**INTRODUCING THE NEW HELLA SPOTLIGHT AND WORKLAMP DISPLAYS**

These displays provide a professional and attractive way to showcase your Hella products. They are designed to be eye-catching and easy to use, making them an ideal choice for your retail environment. The displays are available in a range of sizes and configurations to suit your needs.

HELLA is a specialist manufacturer of halogen and LED lighting products. Our products are designed to meet the needs of the automotive industry, providing superior performance, reliability and safety. We have a long history of innovation and are committed to providing the highest quality products to our customers.

### SOUND INVESTMENT IN SAFETY

**IN THE HUSTLE AND BUSTLE OF TRAFFIC, SAFETY IS PARAMOUNT.**

HELLA Rallye FF provides superior performance and reliability, ensuring your safety on the road. The Rallye FF is designed to provide superior performance, reliability and safety. It is a specialist manufacturer of halogen and LED lighting products. Our products are designed to meet the needs of the automotive industry, providing superior performance, reliability and safety. We have a long history of innovation and are committed to providing the highest quality products to our customers.

### HALOGEN IN ITS BRIGHTEST FORM

**LUMINATOR X, USED ALL OVER THE WORLD, UNDER THE MOST EXTREME CONDITIONS**

HELLA Luminator X is a specialist manufacturer of halogen and LED lighting products. Our products are designed to meet the needs of the automotive industry, providing superior performance, reliability and safety. We have a long history of innovation and are committed to providing the highest quality products to our customers.

### NEW PACKAGING! GREAT SAME PRODUCT

**WE HAVE JUST UPGRADED OUR PACKAGING**

HELLA is a specialist manufacturer of halogen and LED lighting products. Our products are designed to meet the needs of the automotive industry, providing superior performance, reliability and safety. We have a long history of innovation and are committed to providing the highest quality products to our customers.

### RALLYE FF THE NEW RANGE

**RALLYE FF: The complete elegance of light**

HELLA Rallye FF provides superior performance and reliability, ensuring your safety on the road. The Rallye FF is designed to provide superior performance, reliability and safety. It is a specialist manufacturer of halogen and LED lighting products. Our products are designed to meet the needs of the automotive industry, providing superior performance, reliability and safety. We have a long history of innovation and are committed to providing the highest quality products to our customers.

### HELLA TAXI HORNS

**SOUND INVESTMENT IN SAFETY**

**IN THE HUSTLE AND BUSTLE OF TRAFFIC, SAFETY IS PARAMOUNT.**

HELLA Taxi Horns provide superior performance and reliability, ensuring your safety on the road. The Taxi Horns are designed to provide superior performance, reliability and safety. It is a specialist manufacturer of halogen and LED lighting products. Our products are designed to meet the needs of the automotive industry, providing superior performance, reliability and safety. We have a long history of innovation and are committed to providing the highest quality products to our customers.

### LIGHT UP YOUR SALES!

**INTRODUCING THE NEW HELLA 4 x 4 SPOTLIGHT DISPLAY**

HELLA is a specialist manufacturer of halogen and LED lighting products. Our products are designed to meet the needs of the automotive industry, providing superior performance, reliability and safety. We have a long history of innovation and are committed to providing the highest quality products to our customers.

### HELLA offers you so much more

HELLA is a specialist manufacturer of halogen and LED lighting products. Our products are designed to meet the needs of the automotive industry, providing superior performance, reliability and safety. We have a long history of innovation and are committed to providing the highest quality products to our customers.

**054 - 062**  
 HELLA Automotive South Africa  
 June 2011 / May 2012  
 Advertisements design -  
 CMYK Printed. Artwork + Copy

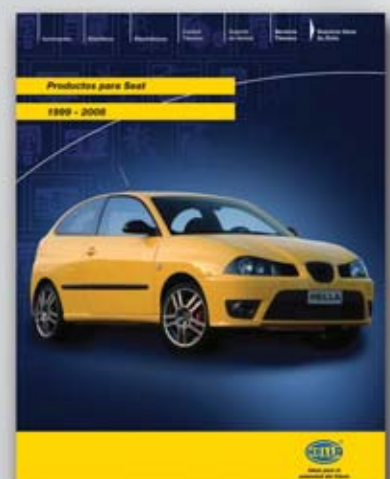
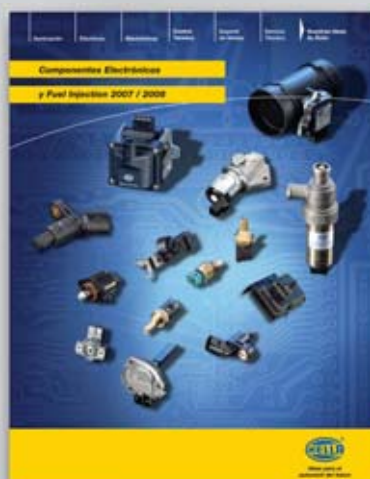
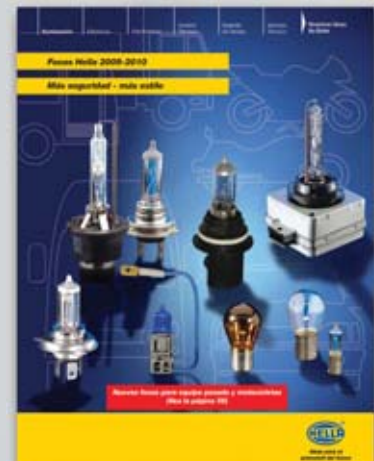
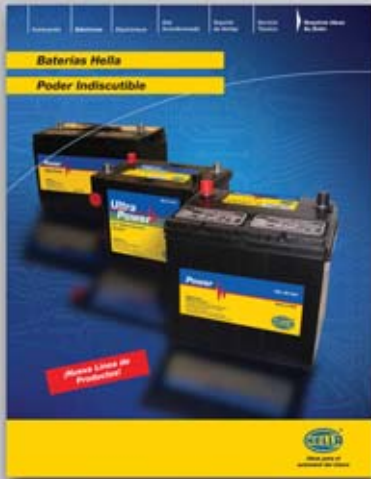

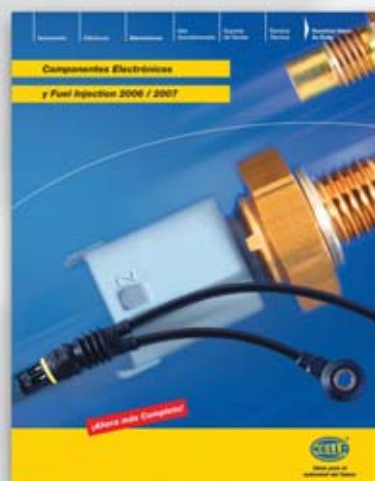
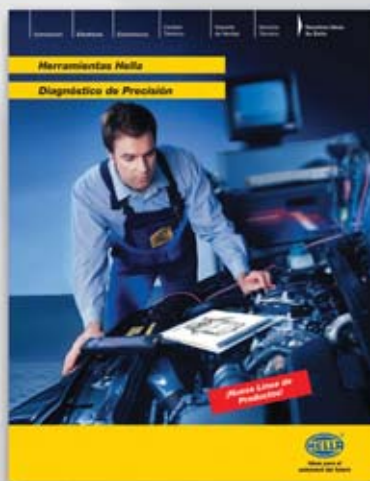
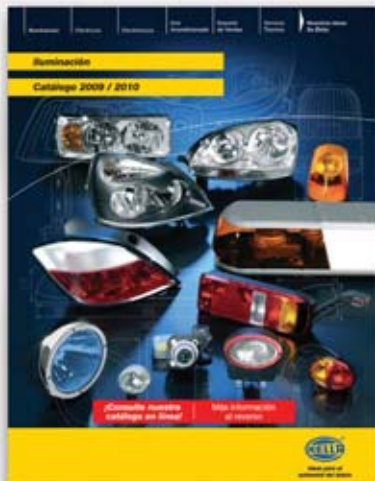
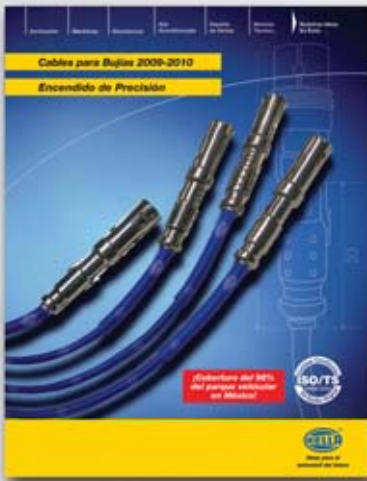

063 - 079

Hellamex, S. A. de C.V.  
2008- 2011

Catalogs design - CMYK Printed.  
Artwork + Copy

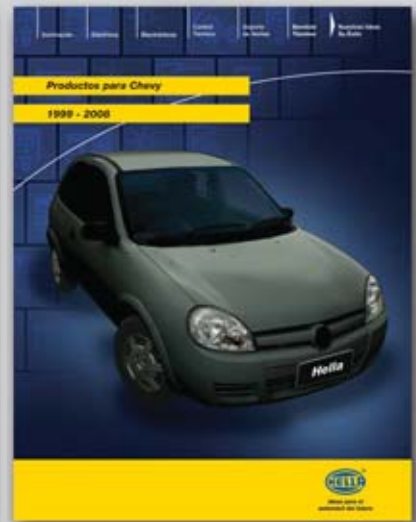
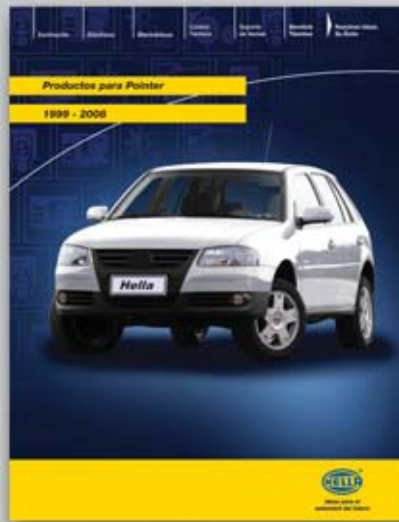
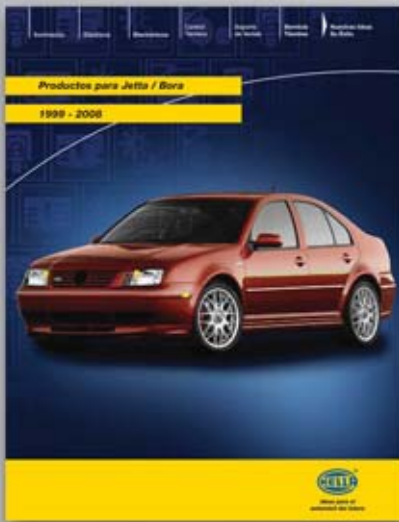
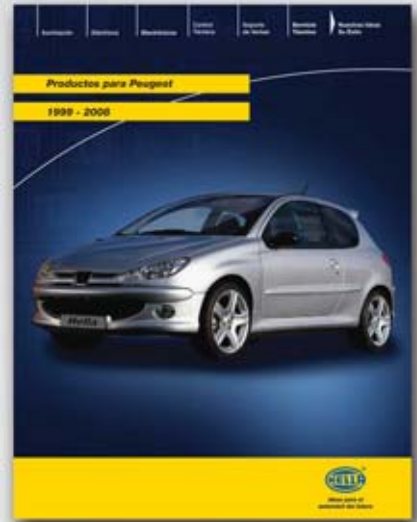
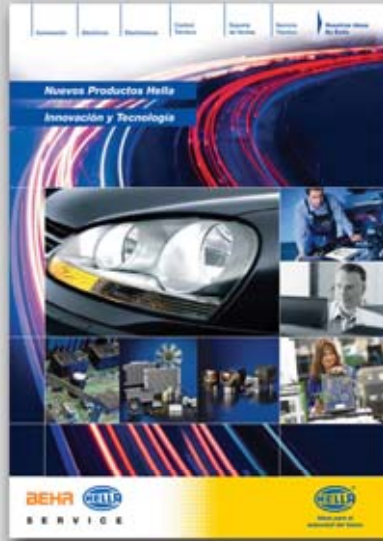

080 - 087

Hellamex, S. A. de C.V.  
2008- 2011

Brochures design - CMYK Printed.  
Artwork + Copy

**Anticongelante / Refrigerante Hella**  
**Temperatura Óptima para su Motor**

**¡Recomendado por los principales fabricantes de autos!**

**HELLA**  
 Más para el automóvil del futuro

**Nuevas Baterías Hella**  
**Libres de Mantenimiento**  
**¡Poder Indiscutible!**

**¡Con garantía total de 50 Meses!**

**HELLA**  
 Más para el automóvil del futuro

**Relays / Relevadores Hella**  
**Óptimos para Instalaciones Eléctricas Profesionales**

**¡Calidad Indiscutible!**

**HELLA**  
 Más para el automóvil del futuro

**Sistema Modular de Iluminación Frontal y Trasera Hella**

**¡Soluciones Personalizadas!**

**HELLA**  
 Más para el automóvil del futuro

**Flashers / Destelladores Hella**  
**Mayor Duración con la Máxima Calidad**

**¡Destellando Seguridad!**

**HELLA**  
 Más para el automóvil del futuro

**Sensores de Oxígeno Hella**  
**Desempeño óptimo**

**¡Hella recomienda con el mejor ambiente!**

01-800-221-0471  
**SERVICIO TÉCNICO GRATUITO**

**HELLA**  
 Más para el automóvil del futuro

**Bulbos de Motoventilador Hella**  
**Precisión en Temperatura**

**¡La Gama más completa!**

088 - 94

Hellamex, S. A. de C.V.  
 2008- 2011

Brochures design - CMYK Printed.  
 Artwork + Copy

Una publicación de Hellamex, S.A. de C.V. - Hellamex 2011 www.hellamex.com

# Hella Noticias

Febrero 19, 2008

**En ésta edición:**  
**HOT NEWS**

- Sistema de Cámara de Reversa
- Sistema de Monitoreo de Presión de Llantas
- Eventos y Exposiciones
- Capacitaciones

**Porque Nuestra Misión es estar más cerca de ti**

Te ofrecemos  
**01-800-221-0471**  
**SERVICIO TÉCNICO GRATUITO**

**Noticias Hella México**  
**Sistema de Cámara de Reversa RVS-1**  
Monitoreo al efectuar maniobras de reversa

El Sistema de Cámara de Reversa RVS-1 hace las maniobras de reversa más sencillas e incrementa la seguridad. La reducción de accidentes reduce a las personas o causar daños es significativo.

El alto desarrollo y la electrónica de la nueva cámara RVS-1, del tamaño de una pila de golf es parte del equipo original en autos de lujo de serie, ideal para autos modernos, vans, SUV's, camionetas, autobuses y camiones. En estos últimos se puede instalar en cualquier, tanto a puerta abierta.

La mini cámara es activada cuando se patea el acelerador la reversa, proyecta una imagen real de la parte trasera del vehículo directamente en la cabina a través del monitor de alta resolución.

La cámara tiene un ángulo de visión de 120° verticalmente y de 120° horizontalmente. Esto hace posible ver la parte posterior de vehículos adyacentes.

La Cámara de Reversa Hella tiene visión nocturna, que combinada con la luz de reversa es suficiente para transmitir una imagen clara al motor.

El Sistema de Cámara de Reversa de aplicación universal incluye:

Cámara de reversa con sensor para alimentación de 12V y salida de video NTSC, modelo T17 69/12.8 cm y lente por ensamblado.

Nº. de Parte 90508981

Widmex en www.hellamex.com

Cámara de Reversa con sensor para alimentación de 12V y salida de video

Visualización de la parte trasera del vehículo

Para SUV's y camionetas

Para camiones

Una publicación de Hellamex, S.A. de C.V. - Hellamex 2011 www.hellamex.com

# Hella Noticias

Marzo 25, 2008

**En ésta edición:**  
**HOT NEWS**

- Sistemas de Advertencia Seguridad y Trabajo
- Flashers/ Deslalladores
- Capacitaciones

**Porque Nuestra Misión es estar más cerca de ti**

Te ofrecemos  
**01-800-221-0471**  
**SERVICIO TÉCNICO GRATUITO**

**Noticias Hella México**  
**Sistemas de Advertencia, Seguridad y Trabajo**

Los Tornos K.LED son extremadamente durables con un sistema confiable y un diseño innovador gracias a la alta calidad de sus componentes. Debido a las aplicaciones con las que están elaborados la base y el capullo, son muy resistentes a la corrosión en condiciones salinas.

Los focos de señalización LED son altamente eficientes y durables debido a la calidad de sus componentes, diseño compacto y robusto, sus excelentes prestaciones de luz, gracias al sistema de 12 LED a de alto rendimiento por luz.

La luz de advertencia ultra durable Duraflex está diseñada para aplicaciones de minería y construcción, donde el tiempo de trabajo es largo y la seguridad es primordial. La carcasa y el lente son resistentes a fuertes impactos gracias a la estructura y materiales con la que está construida.

El CMS-CE cubre anchos de hasta 2,200 mm y ofrece innovadoras características tecnológicas. El atractivo diseño plano permite opciones de montaje y fijación individuales gracias a su estructura modular. Tiene un armazón y moldeo de plástico con panel central blanco y cupulas amarillas. Además de posibilidades de configuración individual.

Consulte nuestros catálogos en línea, Hellamex en www.hellamex.com

K.LED Torno de disco con anillo

PL LED Luzes de señalización LED

Dura-Flex

CMS-CE de Hella

Una publicación de Hellamex, S.A. de C.V. - Hellamex 2011 www.hellamex.com

# Hella Noticias

Septiembre 10, 2008

**En ésta edición:**  
**HOT NEWS**

- Hella ayuda a los consumidores en Tabasco
- Capacitaciones

**Porque Nuestra Misión es estar más cerca de ti**

Te ofrecemos  
**01-800-221-0471**  
**SERVICIO TÉCNICO GRATUITO**

**Noticias Hella México**  
**Hella ayuda a los consumidores en Tabasco**

Hella ayuda a los consumidores en Tabasco. El departamento de atención al cliente de Hella México, en colaboración con el gobierno del estado de Tabasco, realizó una campaña de información para ayudar a los consumidores a elegir el producto adecuado para sus necesidades.

Una publicación de Hellamex, S.A. de C.V. - Hellamex 2011 www.hellamex.com

# Hella Noticias

Septiembre 10, 2008

**En ésta edición:**  
**HOT NEWS**

- Hella ayuda a los consumidores en Tabasco
- Capacitaciones

**Porque Nuestra Misión es estar más cerca de ti**

Te ofrecemos  
**01-800-221-0471**  
**SERVICIO TÉCNICO GRATUITO**

**Noticias Hella México**  
**Un albedo luminoso atrae a los consumidores**

Un albedo luminoso atrae a los consumidores. El departamento de atención al cliente de Hella México, en colaboración con el gobierno del estado de Tabasco, realizó una campaña de información para ayudar a los consumidores a elegir el producto adecuado para sus necesidades.

Una publicación de Hellamex, S.A. de C.V. - Hellamex 2011 www.hellamex.com

# Hella Noticias

Septiembre 10, 2008

**En ésta edición:**  
**HOT NEWS**

- Hella ayuda a los consumidores en Tabasco
- Capacitaciones

**Porque Nuestra Misión es estar más cerca de ti**

Te ofrecemos  
**01-800-221-0471**  
**SERVICIO TÉCNICO GRATUITO**

**Noticias Hella México**  
**Reforzamiento de la participación de Hellamex en el APAC Automotriz 2007**

Reforzamiento de la participación de Hellamex en el APAC Automotriz 2007. El departamento de atención al cliente de Hella México, en colaboración con el gobierno del estado de Tabasco, realizó una campaña de información para ayudar a los consumidores a elegir el producto adecuado para sus necesidades.

Una publicación de Hellamex, S.A. de C.V. - Hellamex 2011 www.hellamex.com

# Hella Noticias

Septiembre 10, 2008

**En ésta edición:**  
**HOT NEWS**

- Hella ayuda a los consumidores en Tabasco
- Capacitaciones

**Porque Nuestra Misión es estar más cerca de ti**

Te ofrecemos  
**01-800-221-0471**  
**SERVICIO TÉCNICO GRATUITO**

**Noticias Hella México**  
**Hella Servicio Técnico**

Hella Servicio Técnico. El departamento de atención al cliente de Hella México, en colaboración con el gobierno del estado de Tabasco, realizó una campaña de información para ayudar a los consumidores a elegir el producto adecuado para sus necesidades.

Una publicación de Hellamex, S.A. de C.V. - Hellamex 2011 www.hellamex.com

# Hella Noticias

Septiembre 10, 2008

**En ésta edición:**  
**HOT NEWS**

- Hella ayuda a los consumidores en Tabasco
- Capacitaciones

**Porque Nuestra Misión es estar más cerca de ti**

Te ofrecemos  
**01-800-221-0471**  
**SERVICIO TÉCNICO GRATUITO**

**Noticias Hella México**  
**Hella en ANAC Expo Transporte 2008**

Hella en ANAC Expo Transporte 2008. El departamento de atención al cliente de Hella México, en colaboración con el gobierno del estado de Tabasco, realizó una campaña de información para ayudar a los consumidores a elegir el producto adecuado para sus necesidades.

Una publicación de Hellamex, S.A. de C.V. - Hellamex 2011 www.hellamex.com

# Hella Noticias

Septiembre 10, 2008

**En ésta edición:**  
**HOT NEWS**

- Hella ayuda a los consumidores en Tabasco
- Capacitaciones

**Porque Nuestra Misión es estar más cerca de ti**

Te ofrecemos  
**01-800-221-0471**  
**SERVICIO TÉCNICO GRATUITO**

**Noticias Hella México**  
**Un salón con Hella Evento especial**

Un salón con Hella Evento especial. El departamento de atención al cliente de Hella México, en colaboración con el gobierno del estado de Tabasco, realizó una campaña de información para ayudar a los consumidores a elegir el producto adecuado para sus necesidades.

Una publicación de Hellamex, S.A. de C.V. - Hellamex 2011 www.hellamex.com

# Hella Noticias

Septiembre 10, 2008

**En ésta edición:**  
**HOT NEWS**

- Hella ayuda a los consumidores en Tabasco
- Capacitaciones

**Porque Nuestra Misión es estar más cerca de ti**

Te ofrecemos  
**01-800-221-0471**  
**SERVICIO TÉCNICO GRATUITO**

**Noticias Hella México**  
**Recepción de los premios ISO 9001:2000 para Hellamex**

Recepción de los premios ISO 9001:2000 para Hellamex. El departamento de atención al cliente de Hella México, en colaboración con el gobierno del estado de Tabasco, realizó una campaña de información para ayudar a los consumidores a elegir el producto adecuado para sus necesidades.

Una publicación de Hellamex, S.A. de C.V. - Hellamex 2011 www.hellamex.com

# Hella Noticias

Septiembre 10, 2008

**En ésta edición:**  
**HOT NEWS**

- Hella ayuda a los consumidores en Tabasco
- Capacitaciones

**Porque Nuestra Misión es estar más cerca de ti**

Te ofrecemos  
**01-800-221-0471**  
**SERVICIO TÉCNICO GRATUITO**

**Noticias Hella México**  
**Hellamex lanza su nuevo portal en Internet**

Hellamex lanza su nuevo portal en Internet. El departamento de atención al cliente de Hella México, en colaboración con el gobierno del estado de Tabasco, realizó una campaña de información para ayudar a los consumidores a elegir el producto adecuado para sus necesidades.

95 - 104

Hellamex, S. A. de C.V. - 2008- 2011  
Monthly newsletters design (48 issues in 4 years time) CMYK  
Printed - Also electronically distributed . Artwork + Copy

105 - 112

Hellamex, S. A. de C.V.- 2008- 2011  
Verical Advertisements. CMYK Printed.  
Artwork + Copy

**Hella Electrónica**  
**Hella una marca, una solución.**

Amplia línea de productos electrónicos: Baterías, bobinas, inyectores, sensores, accesorios, bombas eléctricas de gasolina, etc.

Flashers / distribuidores Hella. Mayor duración con la misma calidad.

Relays / Reluctancias Hella. Opciones para instalaciones eléctricas personalizadas.

**HELLA**  
Ideas para el automóvil del futuro

Hellamex, S.A. de C.V.  
Pteón No. 30, Pteq. Ind. Nezaucapán, Estado de México, C.P. 53488. Fax: 01 (55) 5300-5435  
Tel. Ventas: 01 (55) 5321-1300  
Servicio Técnico Gratuito: 01 800 221 0471

Consulte nuestro catálogo en línea, foro y blog en:  
[www.hellamex.com](http://www.hellamex.com)

**Hella Electrónica**  
**Su seguridad es primero. Adquiera Plumas Limpiaaparabrisas Hella**

La línea más completa del mercado, cubrimos 99% de las aplicaciones.

Conozca el nuevo Set del Auto Hella, incluye: Líquido Anticongelante, toallas limpiadoras, restaurador de panchaduras, cinta aislante y kit de focos.

**HELLA**  
Ideas para el automóvil del futuro

Hellamex, S.A. de C.V.  
Pteón No. 30, Pteq. Ind. Nezaucapán, Estado de México, C.P. 53488. Fax: 01 (55) 5300-5435  
Tel. Ventas: 01 (55) 5369-2672/2675  
Servicio Técnico Gratuito: 01 800 221 0471

De venta en las principales tiendas de autoaviso y centros de distribución.

Consulte nuestro catálogo en línea, visite:  
[www.hellamex.com](http://www.hellamex.com)

**Iluminación Hella**  
**Accesorios Hella Calidad y Estilo**

Extensa línea de accesorios para iluminación auxiliar.

Amplia línea de focos halógenos y xenón para automóviles y motocicletas.

Sistema de Cámara de Reversa, entre otros accesorios Hella.

**HELLA**  
Ideas para el automóvil del futuro

Hellamex, S.A. de C.V.  
Pteón No. 30, Pteq. Ind. Nezaucapán, Estado de México, C.P. 53488. Fax: 01 (55) 5300-5435  
Tel. Ventas: 01 (55) 5321-1300  
Servicio Técnico Gratuito: 01 800 221 0471

Consulte nuestro catálogo en línea, visite:  
[www.hellamex.com](http://www.hellamex.com)

**Hella Electrónica**  
**Baterías Hella ¡Poder indiscutible!**

¡Con garantía total de 50 meses!

Alto desempeño, confiabilidad y larga vida útil. Le ofrecemos:

**Hella Power**  
Para vehículos ligeros, aplicaciones específicas, amplia cobertura.

**Hella Ultra Power Gel**  
Para aplicaciones especiales (equipados y tuning), con mayor capacidad de arranque CCA, resistente a las vibraciones, vida útil prolongada, soporta mayores accesorios en el vehículo.

**Hella Power Servicio Pesado**  
Libres de mantenimiento. Mayor durabilidad. Fabricadas con CCA superior al impreso en la etiqueta. Garantía total.

**HELLA**  
Ideas para el automóvil del futuro

Hellamex, S.A. de C.V.  
Pteón No. 30, Pteq. Ind. Nezaucapán, Estado de México, C.P. 53488. Fax: 01 (55) 5300-5435  
Tel. Ventas: 01 (55) 5321-1300  
Servicio Técnico Gratuito: 01 800 221 0471

Consulte nuestro catálogo en línea, visite:  
[www.hellamex.com](http://www.hellamex.com)

**Hella Electrónica**  
**Hella una marca, una solución.**

La línea más completa en componentes electrónicos y fuel injection:

- Sensores de temperatura del motor (ECT)
- Sensores de temperatura de carga de aire (ACT/MAF/MET)
- Bombas de inyección
- Sensores de posición del acelerador (TPS)
- Sensores de presión absoluta del motor (MAP)
- Sensores de ángulo Apertura Válvula (CV)
- Sensores de flujo de masa de aire (MAF)
- Sensores de posición de árbol de levas (CMP)
- Sensores de posición del cigüeñal (CKP)
- Sensores de detección ABS
- Sensores de velocidad (VSS)
- Sistemas de posicionamiento en la vía (GPS/GPS)
- Válvulas de control de aire acondicionado de ventanilla (AC/ACTIVITY FREQ)
- Válvulas de inyección de gases de escape (GPF)
- Inyectores de combustible
- Moduladores de posición
- Bombas eléctricas de combustible

**HELLA**  
Ideas para el automóvil del futuro

Hellamex, S.A. de C.V.  
Pteón No. 30, Pteq. Ind. Nezaucapán, Estado de México, C.P. 53488. Fax: 01 (55) 5300-5435  
Tel. Ventas: 01 (55) 5321-1300  
Servicio Técnico Gratuito: 01 800 221 0471

Visite nuestro catálogo en línea, blog y foro en:  
[www.hellamex.com](http://www.hellamex.com)

**Hella Electrónica**  
**Hella una marca, una solución.**

Amplia línea de productos electrónicos: Sensores, bobinas, inyectores, sensores, accesorios, etc.

Cables para todos. Con aplicaciones para los principales vehículos en México.

Dispositivos, focos, inyectores y distribuidores con calidad de equipo original.

**HELLA**  
Ideas para el automóvil del futuro

Hellamex, S.A. de C.V.  
Pteón No. 30, Pteq. Ind. Nezaucapán, Estado de México, C.P. 53488. Fax: 01 (55) 5300-5435  
Tel. Ventas: 01 (55) 5321-1300  
Servicio Técnico Gratuito: 01 800 221 0471

Consulte nuestro catálogo en línea, visite:  
[www.hellamex.com](http://www.hellamex.com)

**Accesorios Hella**  
**Personaliza tu vehículo**

Focos Principales

Cabeceras

Focos de Luz de Día

Mayor seguridad con los focos de luz de día y bene con luz de noche.

Extensa línea de focos auxiliares con tecnología halógena, xenón y LED.

**HELLA**  
Ideas para el automóvil del futuro

Hellamex, S.A. de C.V.  
Pteón No. 30, Pteq. Ind. Nezaucapán, Estado de México, C.P. 53488. Fax: 01 (55) 5300-5435  
Tel. Ventas: 01 (55) 5321-1300  
Servicio Técnico Gratuito: 01 800 221 0471

Visite nuestro catálogo en línea, blog y foro en:  
[www.hellamex.com](http://www.hellamex.com)

**Promociones Hella**  
**Reto de Pascuas Hella HELIX**

el mecánico estrella de Hella te invita:

El reto es ayudar a Hella a encontrar los adornos de Pascuas (Antes de que su nueva Hella note que están perdidos)

Consulta las bases del reto en:  
[www.hellamex.com](http://www.hellamex.com)  
de Febrero 16 al 31 de Marzo 2009

El tiempo es corto, ¡Ayúdame a encontrar! Grandes premios te esperan.

**HELLA**  
Ideas para el automóvil del futuro

Hellamex, S.A. de C.V.  
Tel. Ventas: 01 (55) 5321-1300  
Servicio Técnico Gratuito: 01 800 221 0471

Visite nuestro catálogo en línea, blog y foro en:  
[www.hellamex.com](http://www.hellamex.com)



113

Hellamex, S. A. de C.V.- 2006

Festive seasons card.

CMYK Printed - Also electronically distributed . Artwork + Copy



114

Hellamex, S. A. de C.V. - 2008

Festive seasons card.

CMYK Printed - Also electronically distributed . Artwork + Copy



**Faros Luz de Día Hella**  
Conducción segura a todo momento

**Seguridad y eficiencia**

Los faros de Luz de Día Hella mejoran la visibilidad y reducen el consumo de energía. Son compatibles con los sistemas de frenado antibloqueo (ABS) y los sistemas de control de estabilidad (ESP).

Los faros de Luz de Día Hella mejoran la visibilidad y reducen el consumo de energía. Son compatibles con los sistemas de frenado antibloqueo (ABS) y los sistemas de control de estabilidad (ESP).

**Hella**  
Una marca que garantiza la calidad y la seguridad.

01 200 5221-1300  
01 800 221-0471  
www.hella.com

**Anticongelante / Refrigerante Hella**  
Temperatura óptima para su motor

**Seguridad y eficiencia**

El anticongelante Hella protege su motor y evita el sobrecalentamiento. Es compatible con los sistemas de frenado antibloqueo (ABS) y los sistemas de control de estabilidad (ESP).

El anticongelante Hella protege su motor y evita el sobrecalentamiento. Es compatible con los sistemas de frenado antibloqueo (ABS) y los sistemas de control de estabilidad (ESP).

**Hella**  
Una marca que garantiza la calidad y la seguridad.

01 200 5221-1300  
01 800 221-0471  
www.hella.com

**Plumas Limpiaparabrisas Hella**  
Porque tu seguridad es primero

**Seguridad y eficiencia**

Las plumas Hella limpian el parabrisas de manera eficiente y segura. Son compatibles con los sistemas de frenado antibloqueo (ABS) y los sistemas de control de estabilidad (ESP).

Las plumas Hella limpian el parabrisas de manera eficiente y segura. Son compatibles con los sistemas de frenado antibloqueo (ABS) y los sistemas de control de estabilidad (ESP).

**Hella**  
Una marca que garantiza la calidad y la seguridad.

01 200 5221-1300  
01 800 221-0471  
www.hella.com

**Personaliza tu vehículo**  
Productos Hella con calidad de equipo original

**Innovación, seguridad y conciencia ambiental**

Los productos Hella personalizan tu vehículo con calidad de equipo original. Son compatibles con los sistemas de frenado antibloqueo (ABS) y los sistemas de control de estabilidad (ESP).

Los productos Hella personalizan tu vehículo con calidad de equipo original. Son compatibles con los sistemas de frenado antibloqueo (ABS) y los sistemas de control de estabilidad (ESP).

**Hella**  
Una marca que garantiza la calidad y la seguridad.

01 200 5221-1300  
01 800 221-0471  
www.hella.com

**Accesorios Hella**  
Iluminación Extrema

**Innovación Tecnológica**

Los accesorios Hella mejoran la iluminación de tu vehículo. Son compatibles con los sistemas de frenado antibloqueo (ABS) y los sistemas de control de estabilidad (ESP).

Los accesorios Hella mejoran la iluminación de tu vehículo. Son compatibles con los sistemas de frenado antibloqueo (ABS) y los sistemas de control de estabilidad (ESP).

**Hella**  
Una marca que garantiza la calidad y la seguridad.

01 200 5221-1300  
01 800 221-0471  
www.hella.com

**Accesorios Hella**  
Iluminación Extrema

**Innovación Tecnológica**

Los accesorios Hella mejoran la iluminación de tu vehículo. Son compatibles con los sistemas de frenado antibloqueo (ABS) y los sistemas de control de estabilidad (ESP).

Los accesorios Hella mejoran la iluminación de tu vehículo. Son compatibles con los sistemas de frenado antibloqueo (ABS) y los sistemas de control de estabilidad (ESP).

**Hella**  
Una marca que garantiza la calidad y la seguridad.

01 200 5221-1300  
01 800 221-0471  
www.hella.com

**Soluciones Personalizadas**

**Seguridad y eficiencia**

Las soluciones personalizadas Hella mejoran la seguridad y la eficiencia de tu vehículo. Son compatibles con los sistemas de frenado antibloqueo (ABS) y los sistemas de control de estabilidad (ESP).

Las soluciones personalizadas Hella mejoran la seguridad y la eficiencia de tu vehículo. Son compatibles con los sistemas de frenado antibloqueo (ABS) y los sistemas de control de estabilidad (ESP).

**Hella**  
Una marca que garantiza la calidad y la seguridad.

01 200 5221-1300  
01 800 221-0471  
www.hella.com

**Hella le ofrece productos en iluminación, Eléctricos, Electrónicos y Control Térmico con calidad de equipo original.**

**Hella una marca, una solución.**

Los productos Hella mejoran la iluminación, eléctrica, electrónica y el control térmico de tu vehículo. Son compatibles con los sistemas de frenado antibloqueo (ABS) y los sistemas de control de estabilidad (ESP).

Los productos Hella mejoran la iluminación, eléctrica, electrónica y el control térmico de tu vehículo. Son compatibles con los sistemas de frenado antibloqueo (ABS) y los sistemas de control de estabilidad (ESP).

**Hella**  
Una marca que garantiza la calidad y la seguridad.

01 200 5221-1300  
01 800 221-0471  
www.hella.com

115-122  
Hellamex, S. A. de C.V.  
Advertisement - Full page  
CMYK Printed.

# PACKAGING



# Packaging Design

Boxes, plastic packaging, labels  
and limited edition packaging.

CONCEPTS  
PACKAGED

# 123

HELLA

Illustration + Artwork design and packaging concept  
 CYMK + silver foil.

The introduction of the HELLA Synthetic Oil into the Mexican market was a great success. The combination and design and metallic finish in the label created a great visual impact in the consumer.

The revenue of this product annually is more than 5 million USD per year and it will continue growing in the following years to come.



124

HELLA

Illustration + Artwork design and packaging concept  
CYMK .

The all new HELLA Northern Lights incorporates a unique technology: the RGB LED accent light that changes color using an app available online.

This product is sold in 23 different countries with a lot of expectation created by displays and the packaging itself.





# 125

Hella Sintetic Oil, Coolant/Anti-Freeze, Oil transmission - Labels design  
 5 L , 946 ml and 350 ml packages  
 Artwork design and packaging concept - CMYK + metallic foil + UV varnish



# 126

Hella Halogen and Miniature bulbs range  
 Artwork design and packaging concept - CMYK



# 127

Hella Wiper Blades - Standard and Rear  
 Artwork design and packaging concept - CYMK



# 128

Hella High Performance halogen bulbs  
 Artwork design and packaging concept - CYMK

# 129

**Hella Spark plug cables**  
 Artwork design and packaging concept  
 CMYK + cardboard.



# 130

**Hella South Africa - High performance bulbs**  
 Artwork design and packaging concept  
 CMYK + metallic foil + UV varnish



# 131

Hella - Wiper blade frameless  
 Artwork design and packaging concept  
 CMYK + metallic foil - card board.



International packaging roll out to Asia region: China, Hong Kong, Malaysia, Taiwan, Singapore and India.



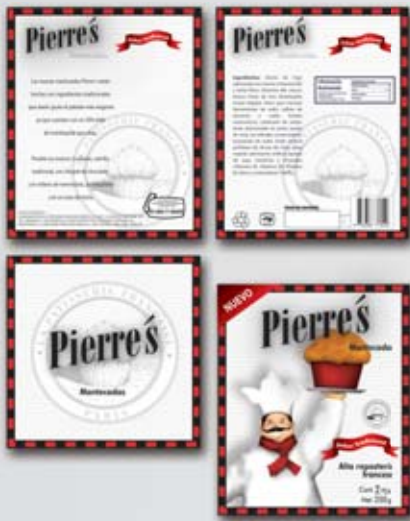

132

Pierres - La Patiserie Francaise.  
Illustration + Artwork design and packaging concept  
CYMK + silver cardboard.



133

Napolis- Milky Chocolate  
Artwork design and packaging concept  
CYMK + metallic foil



# 134

## Tacon Maiz

Artwork design and packaging concept  
 CYMK + cardboard.



# 135

## Papinni - Fried chips

Artwork design and packaging concept  
 CYMK



# 137

**HELLA Automotive Sales Inc.**  
 Automotive bulbs packaging for retail  
 More than 100 different models  
 Artwork design and packaging concept  
 CYMK + Cardboard + Plastic blister





# 137

**BERU AG.**

Automotive bulbs packaging -  
 More than 60 different models  
 Artwork design and packaging concept  
 CMYK + Cardboard + UV Matt finish.

# 138

Hella Mexico - Blister pack - High performance bulbs  
Artwork design and packaging concept  
CYMK + cardboard.



# 139

Hella South Africa - Trumpet Horn packaging  
Artwork design and packaging concept  
CYMK + corrugated E flute

# 140

Hellamex, S. A. de C.V. - Automotive set  
 Artwork design and packaging concept  
 CYMK



- Air Freshener
- Windshield Liquid Cleaner
- Flat Tire Restorer
- Cleaning Wipes for Auto Surfaces



# 141

Hella South Africa - Auxiliary Lighting packaging  
 Artwork design and packaging concept  
 CYMK + corrugated E flute

# 142

HELLA Automotive Sales, Inc.  
Artwork design and packaging concept  
CYMK + silver cardboard.







143

Alterra

Artwork design and packaging concept

CYMK



144

HELLA Automotive Sales, Inc.

Artwork design and packaging concept

CYMK



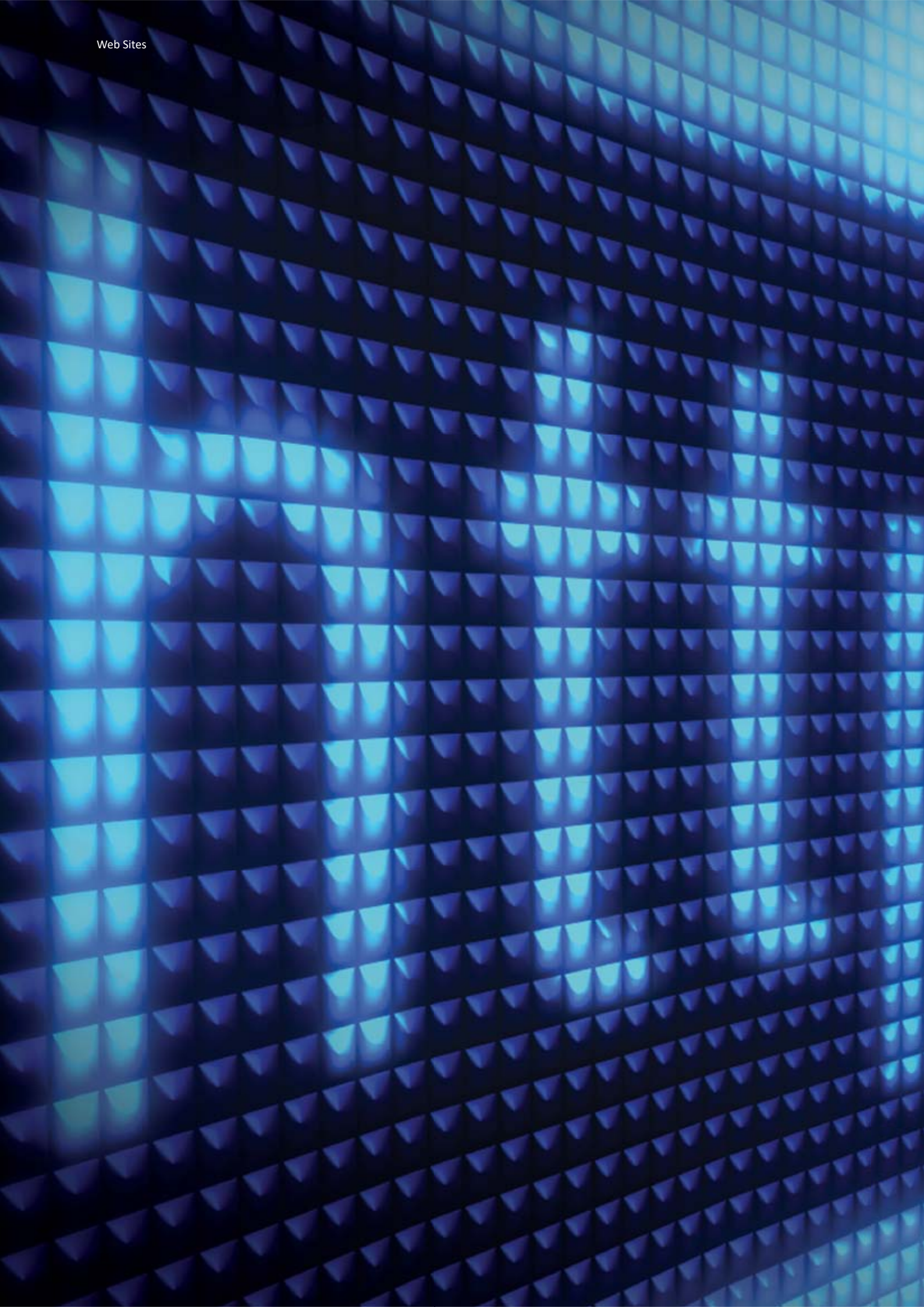

# Web Sites

Corporate websites, banners  
and e-newsletter.

READY AND  
ON-LINE

# 145

Giftwrap - Packaging Services  
 Web site design (HTML / Flash) - Concept  
 RGB



# 146

**ENDIT - National Soccer Managers School**  
 Web site design (HTML / Flash) - Concept  
 RGB



# 147

JJHF - Ingeniería y Asociados - Insulation product  
 Web site design (HTML / Flash) - Concept  
 RGB



# 148

**Violeta Medrano - Jewelry Designer**  
 Web site design (HTML / Flash) - Concept  
 RGB



# 149

Qualcomm - Omnictracs (logistics product and devices)  
 Web site design (HTML / Flash) - Concept  
 RGB





# 150

Volvo Trucks - Internet Banners  
Flash- RGB



# 151

The Creative Workshop  
Web site design (HTML / Flash) - Concept  
RGB







# Video and Interactive Media

Interactive content, electronic  
presentations and corporate videos.

CUTTING EDGE  
NEW MEDIA

Iluminación | Eléctricos | Electrónicos | Aire Acondicionado | Soporte de Ventas | Servicio Técnico | Nuestras Ideas, Su Éxito

Catálogos y Folletos

Salir

**Eléctricos**

- Relevadores
- Plumas Limpiaparabrisas
- Claxones y Bocinas

01-800 221 0471

SERVICIO TÉCNICO GRATUITO

de 8:00 AM a 17:30 PM. Nuestro servicio técnico

← Regresar a Menu Principal

**Perfil de Productos Hella Eléctricos**

Iluminación | Eléctricos | Electrónicos | Aire Acondicionado | Soporte de Ventas | Servicio Técnico | Nuestras Ideas, Su Éxito

Aire Acondicionado

Eléctricos

Salir

Catálogos y Folletos

01-800 221 0471

SERVICIO TÉCNICO GRATUITO

de 8:00 AM a 17:30 PM. Nuestro servicio técnico

← Regresar a Menu Principal

**Perfil de Productos Hella**

Iluminación | Eléctricos | Electrónicos | Aire Acondicionado | Soporte de Ventas | Servicio Técnico | Nuestras Ideas, Su Éxito

Aire Acondicionado

Eléctricos

Salir

Catálogos y Folletos

01-800 221 0471

SERVICIO TÉCNICO GRATUITO

de 8:00 AM a 17:30 PM. Nuestro servicio técnico

← Regresar a Menu Principal

**Perfil de Productos Hella**

Iluminación | Eléctricos | Electrónicos | Aire Acondicionado | Soporte de Ventas | Servicio Técnico | Nuestras Ideas, Su Éxito

Iluminación

- Faros
- Luces de Posición
- Lámparas Rotativas
- Faros

Salir

Catálogos y Folletos

01-800 221 0471

SERVICIO TÉCNICO GRATUITO

de 8:00 AM a 17:30 PM. Nuestro servicio técnico

← Regresar a Menu Principal

**Perfil de Productos Hella Iluminación**

Iluminación | Eléctricos | Electrónicos | Aire Acondicionado | Soporte de Ventas | Servicio Técnico | Nuestras Ideas, Su Éxito

Monitor Filtro de Escapes

Monitor Componentes Compresores

Monitor Sistema EGR

Monitor Sistema de Combustible

Monitor Sistema FAP

Salir

Catálogos y Folletos

01-800 221 0471

SERVICIO TÉCNICO GRATUITO

de 8:00 AM a 17:30 PM. Nuestro servicio técnico

← Regresar a Menu Principal

**Perfil de Productos Hella Electrónicos**

**HELLA** *Visión para el automóvil del futuro*

Soporte de Ventas | Servicio Técnico

Iluminación | Electrónica | Electrónica | Aire Acondicionado

Perfil de Productos Hella  
CD-ROM Interactivo - Inicio  
Catálogos

Light Driver  
Juego Interactivo - Instalador  
Protector de Pantalla

Instalador QuickTime™ Player  
Instalador Acrobat Reader™

Información Legal  
Este CD-ROM interactivo requiere tener instalado la versión más reciente de QuickTime™ Player  
© 1999 Hella KGaA Hueck & Co. • Hellamex, S.A. de C.V. 2000  
© 2000 The Autodesk Company. Todos los derechos reservados.

**HELLA** *Visión para el automóvil del futuro* **Iluminación**

Historia y Normas

**HELLA 540**  
En 1906 comienza su producción

Reflector plateado  
Flama de oscilación  
Lente de cristal con fondo plateado  
Lente de cristal

Primer Faro con Marca Hella

Anterior | Siguiente

© Hella KGaA Hueck & Co. 2000 | Hella Técnica

**HELLA** *Visión para el automóvil del futuro* **Iluminación**

→ Lámparas Hella  
→ DMS (Sistemas ópticos de advertencia)  
→ Lámparas KL Junior  
→ Lámparas KL Rotativas/Pluviófaros  
→ Lámparas KL 7300 y 8000

→ Componentes Técnicos  
→ Lámparas Duralight  
→ Lámparas K LRS

**Hella, su aliado en Iluminación de alto rendimiento**

Lámparas Rotativas y Sistemas Ópticos de Advertencia  
Menu Secundario

¿ Precisa los Datos para más información?

© Hella KGaA Hueck & Co. 2000 | Hella Técnica

**HELLA** *Visión para el automóvil del futuro* **Iluminación**

Factores de Influencia/Componentes

Encendido del foco  
Sobrevoltaje  
Alto nivel de luminosidad

Stress mecánico  
presión / vibración

Llenado a presión  
llenado de gas  
positivo / negativo

Factores que influyen en los focos

Anterior | Siguiente

© Hella KGaA Hueck & Co. 2000 | Hella Técnica

**HELLA** *Visión para el automóvil del futuro* **Electrónicos**

Hella Comercial

Anterior | Siguiente

Cada vez hay más productos Electrónicos en los autos  
Hoy en día 30% del Auto son componentes electrónicos

Tendencias del Mercado en Todo el Mundo

Anterior | Siguiente

© Hella KGaA Hueck & Co. 2000 | Hella Comercial

**HELLA** *Visión para el automóvil del futuro*

Hella Comercial Iluminación | Hella Técnica Perfil de Productos Hella | Catálogos y Folletos Información Impresa

© Hella KGaA Hueck & Co. 2000

**HELLA** *Visión para el automóvil del futuro* **Electrónicos**

Sist. Falsa Encendido | Monitor del Sistema | Falsa Probadora | Diagnostico | Comparación | Soluciones

**Monitor de Detección de Falta de Encendido**  
Condiciones para correr el monitor

Producto  
**Sensor de Masa de Flujo de Aire (MAF)**  
Tipo (termistor)

Función: Es un detector de flujo de aire, electrónicamente mide la cantidad de aire que ingresa al motor, mediante una rejilla de alambre caliente.

Sistema de fallo:  
Exceso de combustible, tuerca negra, tuerca en apriete en válvulas, se enciende la luz de check engine

Diagrama de conexión:

Anterior | Siguiente

Perfil de Productos Hella Electrónicos

152  
Hellamex, S.A. de C.V.  
Interactive CD (Flash + Video + 3D)  
RGB

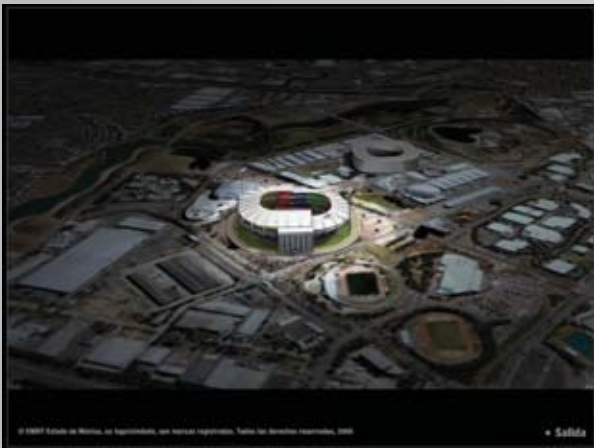



# 153

Mr. Rafael del Moral) - ENDIT  
Interactive CD (Flash + Video + 3D)  
RGB

# 154

ADN-F (Almacenamiento y Distribución Nacional S.A. de C.V.)  
Interactive CD (Flash + Video)  
RGB

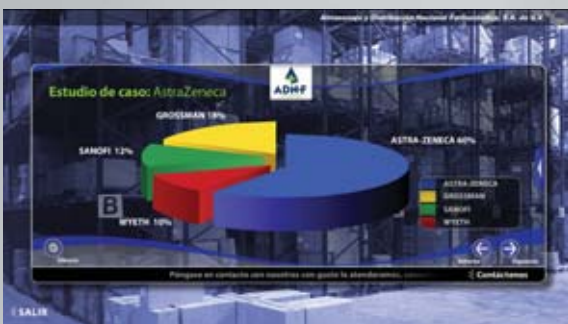

CLIENTE	REPRESENTANTES MÉDICOS			MONTOS DE CALLES		CONTRIBUCIÓN AL MANTENIMIENTO FINANCIERO		
	GRUPO	INDICADOR	ANÁLISIS	PERÍODO DE REFERENCIA	TOTAL DE REGIONES	ANÁLISIS	PERÍODO	%
ASTRA ZENECA	100	411	200	10	1,000	4,000	10,000	100%
MYETH	100	0	100	40	1,000	0	1,000	100%
SANDI	100	0	100	0	1,000	0	1,000	100%
LABORATORIOS GROSMAN	200	0	200	0	1,000	0	1,000	100%
TOTAL REGIONES	400	411	1,000	50	10,000	0	10,000	100%
TOTAL PRODUCTOS	6,000	6,000	12,000	800	100,000	100,000	100,000	100%



# 155

The Creative Workshop  
Interactive CD (Flash + 3D)  
RGB



Video and Interactive Media

**Objetivos**

Ser portavoz de todos los asociados ante autoridades, organismos e instituciones dentro y fuera del sector

Colaboración con PEMEX Refinación y con el Empresario Gasolinero en programas de planeación industrial y comercial

3

**Proyectos Actuales**

**Quiénes somos**

1 El cambio en el concepto de la Franquicia PEMEX y el programa de la modernización de Estaciones de Servicio propiciaron en el sector gasolinero que un número importante de empresas se reunieran con el objetivo de atender las necesidades en materia de tecnología, servicio, diseño y construcción de Estaciones de Servicio en nuestro país

**Beneficios a nuestros socios activos en todas las ramas del sector petrolero**

**Información:**

Listado de Constancias en trámite otorgadas por PEMEX para la construcción de nuevas gasolineras. Incluye nombre, teléfonos y dirección.

1

**Proyectos actuales**

Subcomité de Recuperación de Vapores.

Coordinador: Lic. José Guadalupe Oléa

3

**Socios Activos de AMPES**

# 156

UNILEVER de Mexico, S.A. de CV. - Becel de Capullo  
 Interactive CD (Flash + 3D)  
 RGB

Cuida tu corazón

# Becel de Capullo

PLAY INTRO

La Línea Becel contribuye por la salud de su corazón  
 Sepa más sobre Becel

- Características
- Producto
- Diseño
- Formulación

Más información [www.becel.com](http://www.becel.com)

Salida

Cuida tu corazón

# Becel de Capullo

Más información [www.becel.com](http://www.becel.com)

Salida

MENU PRINCIPAL

## Diseño

Presentación de 400 gr

Autortur

- Características
- Producto
- Formulación

Más información [www.becel.com](http://www.becel.com)

Salida

MENU PRINCIPAL

## Diseño

Autortur

- Características
- Producto
- Formulación

Más información [www.becel.com](http://www.becel.com)

Salida

MENU PRINCIPAL

## Concepto para Innocheck

Para ti, que quieres vivir más y mejor, y que sabes que tu salud y la de tu familia dependen de una buena alimentación, llegó la nueva y rica Margarina Becel Capullo

Autortur

- Producto
- Diseño
- Formulación

Más información [www.becel.com](http://www.becel.com)

Salida

MENU PRINCIPAL

## Formulación

Denominación legal: Margarina

Contenido vitamínico:  
 "E" excelente antioxidante, evita el envejecimiento prematuro de las células.  
 "A" y "D" regeneran los tejidos y mejoran la absorción de calcio y fósforo en huesos

Sabor: cremoso

Autortur

- Características
- Producto
- Diseño

Más información [www.becel.com](http://www.becel.com)

Salida

MENU PRINCIPAL

## Empaque

Tinas rectangulares de 190g, 400g y 800g

Autortur

- Características
- Diseño
- Formulación

Más información [www.becel.com](http://www.becel.com)

Salida

# 157

UNIVEVER de Mexico S.A. de C.V - Knax de Knorr  
 Interactive CD (Flash + 3D)  
 RGB



158

UNILEVER de Mexico, S.A. de CV. - Safetyman  
Interactive CD (Flash + Powepoint + 3D)  
RGB



### Descripción del Evento

Después de aproximadamente los 1000 km, en condiciones de la noche, se trasladaba a recibir a su primer cliente, gracias al control del vehículo y como consecuencia se propuso la volcadura.

El accidente se produce por una decisión de control por el nivel de velocidad al conductor de vehículos involucrado, por parte de un tercero que conduce una camioneta de 15 ton. El conductor al estar de noche al llegar de forma cansada de la caminata sobre un bache derecho, trata de recuperarse de manera momentánea a la carretera "que al instante hacia un bache a la izquierda" por lo que al salir de la camioneta "que al instante hacia un bache a la izquierda" como consecuencia se rebotó la camioneta sobre un bache. Una volcadura se produce que representa un alto riesgo para generar a que el conductor se encuentre en un estado de shock, por lo que se debe brindar atención médica inmediata.

### Causas Inmediatas:

- \* Falta de velocidad adecuada por parte del tercero a suceso de control.
- \* Falta de adherencia / Faltó la adherencia. El pavimento está en mal estado y no existe pintura adherida por debajo de control.

### Causas Básicas:

- \* Falta de habilidad / Falta de habilidad en manejar la camioneta "bache a la izquierda".

### Lecciones aprendidas:

Evitar, etc.

- \* Extremar atención en ojos y mente en la forma de conducir de los terceros y en condiciones que cuentan con control de velocidad.
- \* Partir al volante de seguridad reduce considerablemente la gravedad en los hechos.

**Lecciones Aprendidas: Volcadura**



## SAFETYMAN INFORMA

Enero 2008

Menú Principal

### Menú Principal

2005/0-2007/0 SAFETYMAN

- Objetivos 2008
- Balance Score Card
- ADT's
- Lección Aprendida
- ¿Sabías Qué?
- Agencias Modelo



# 159

**Pfizer - Azitrocin**  
Interactive CD (Flash - Apps)  
RGB



160

PFIZER - Dalacin  
Interactive CD (Flash - Apps)  
RGB

Video and Interactive Media

# 161

DURALFOIL - JJHF Ingenieria y Asociados S.A. de C.V.  
 Interactive CD (Flash - Apps)  
 RGB

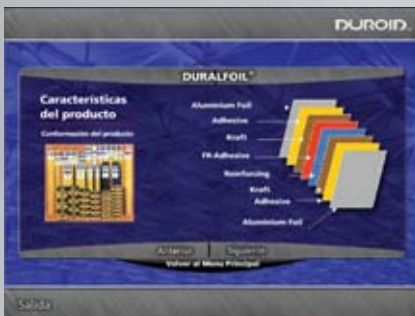



# 162

HELLA Inc. (USA) - F-150 products  
Interactive CD (Flash - Apps)  
RGB

**HELLA** Ideas today for the cars of tomorrow

## Ford F-150

Hella Accessories

Light up your playground with Hella's F-150 Upgrade Kit for 2004-2007 models featuring OE quality, Hella performance and a sleek, new look for your truck

**NEW!**

more

Exit Spanish Version Imprint [www.hellausa.com](http://www.hellausa.com)

HELLA Ideas today for the cars of tomorrow

Hella Accessories Products for Ford F-150

Exit Spanish Version Imprint [www.hellausa.com](http://www.hellausa.com)

HELLA Ideas today for the cars of tomorrow

Hella Accessories Products for Ford F-150

Choose your truck

Exit Spanish Version Imprint [www.hellausa.com](http://www.hellausa.com)

HELLA Ideas today for the cars of tomorrow

Hella Accessories and Parts Products for Ford F-150

**F-150 Blackout Headlamp Kit Features:**

- Provides a sleek look and superior lighting without adding a second beam to your truck. (Standard headlights meet the Federal Motor Vehicle Safety (FMVSS) requirements.)
- The company gets it done with no cutting, grinding or welding and without voiding the warranty for your truck.

**F-150 Series Features:**

- Headlamp & support components (OE quality)
- Complete OE quality mounting kit
- OE quality wiring harness
- OE quality bulbs
- OE quality mounting brackets
- OE quality mounting hardware
- OE quality mounting hardware
- 2004 - 2007

HELLA is a registered trademark of Hella AG. © 2007 Hella AG. All rights reserved.

Exit Spanish Version Imprint [www.hellausa.com](http://www.hellausa.com)

HELLA Ideas today for the cars of tomorrow

Hella Accessories Products for Ford F-150

Model F-150 Quicklook

Back Hella Accessories Enter

Exit Spanish Version Imprint [www.hellausa.com](http://www.hellausa.com)

HELLA Ideas today for the cars of tomorrow

Hella Accessories and Parts Products for Ford F-150

**Hella F-150 Blackout Headlamp Kit Features:**

- Stylish "Blackout" look
- Superior beam spreading
- Carbon Steel insert
- Bulbs not included
- Easy plug & play installation

Blackout Headlamp Kit #20000001

more

Back to Main Menu F-150 Headlamp F-150 Bulbs

Exit Spanish Version Imprint [www.hellausa.com](http://www.hellausa.com)

HELLA Ideas today for the cars of tomorrow

Hella Accessories Products for Ford F-150

More

Back

Back to Main Menu

Exit Spanish Version Imprint [www.hellausa.com](http://www.hellausa.com)

HELLA Ideas today for the cars of tomorrow

Hella Accessories Products for Ford F-150

More

Back

Back to Main Menu

Exit Spanish Version Imprint [www.hellausa.com](http://www.hellausa.com)

HELLA Ideas today for the cars of tomorrow

Hella Tailights Products for Ford F-150

Exit Spanish Version Imprint [www.hellausa.com](http://www.hellausa.com)

HELLA Ideas today for the cars of tomorrow

Hella Accessories Products for Ford F-150

Model F-150 Quicklook

Hella Accessories Enter

Back

Exit Spanish Version Imprint [www.hellausa.com](http://www.hellausa.com)

Video and Interactive Media

# 163

HELLA Automotive South Africa - High Performance Bubs  
Flash animation banners  
RGB

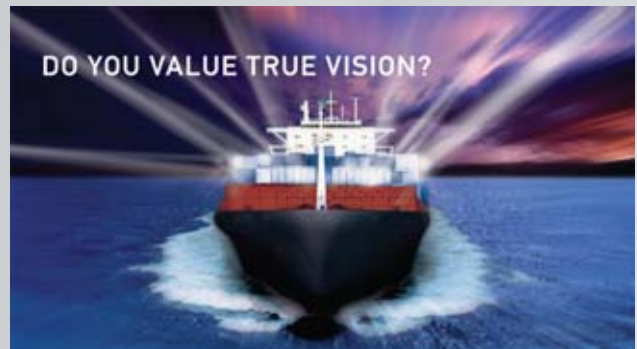

# 164

HELLAMEX - Sales Company report  
Interactive (Flash + 3D)  
RGB

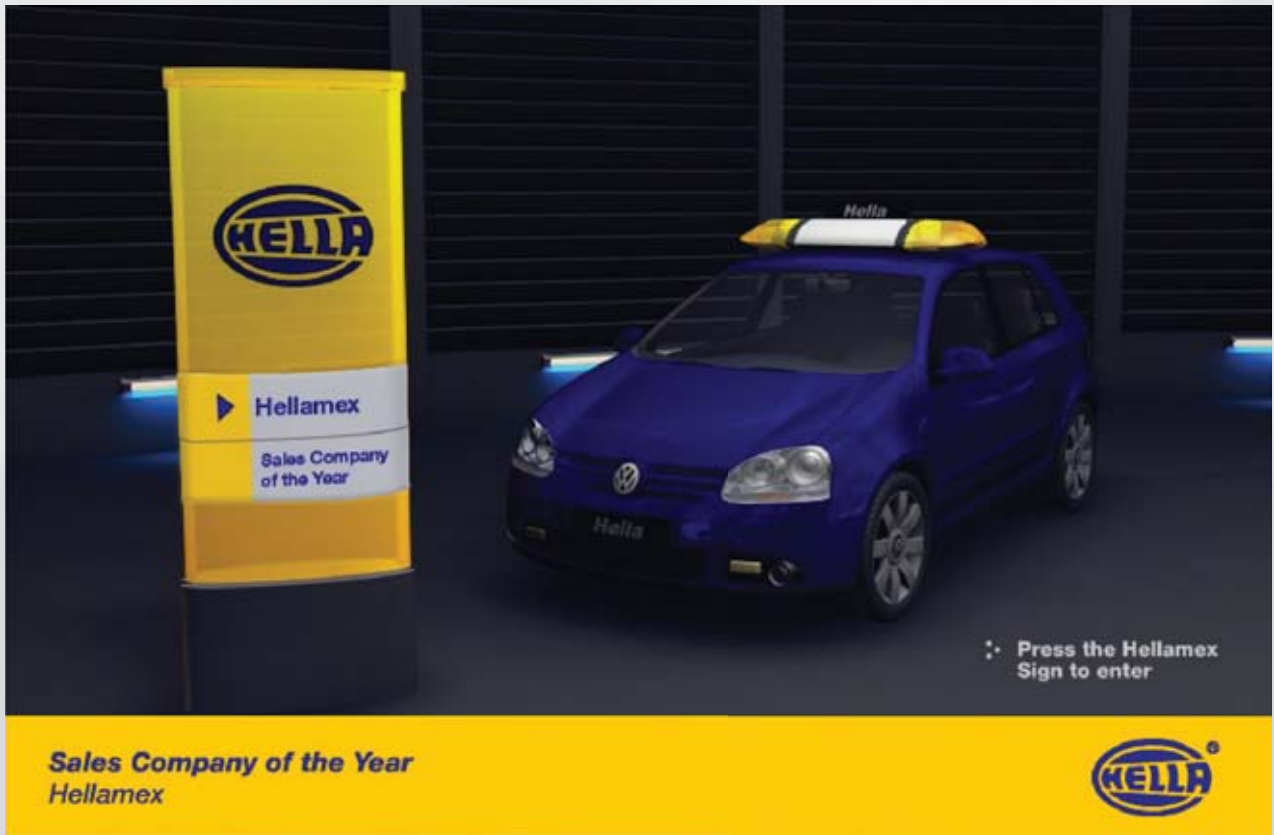

# 165

La Duela TV - TV sport show  
Video (3D - FX)  
RGB





# 166

HELLA PAGID (USA) - High Carbon Brake Rotors  
3D animation + video editing  
RGB

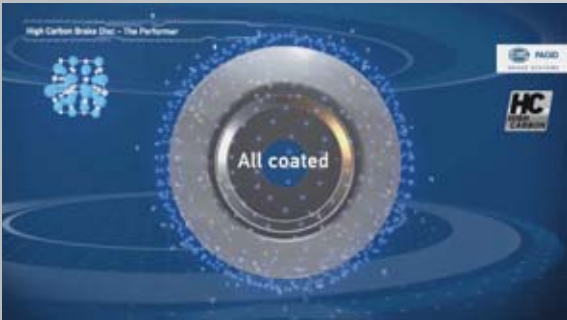
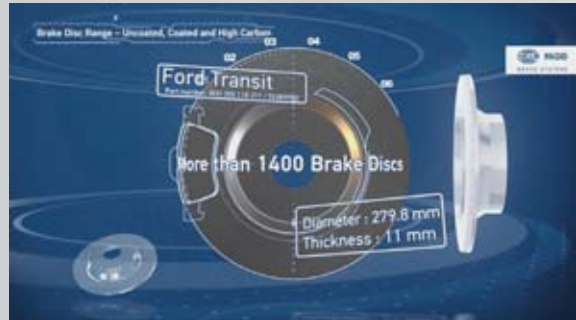

# 167

Hella - High performance bulbs 2.0  
Video (3D - FX)  
RGB



HELLA High Performance 2.0



Production facilities with 100% automated camera controlled process



HELLA High Performance 2.0 halogen bulb kit.  
• Gloves to protect your bulbs  
• Distinctive groove to prevent false contacts  
• HELLA Decal



HELLA High Performance 2.0 halogen bulbs







# Exhibitions and POP Materials

Point of purchase materials, stands  
design and furniture.

ATTRACTION TO  
CUSTOMERS



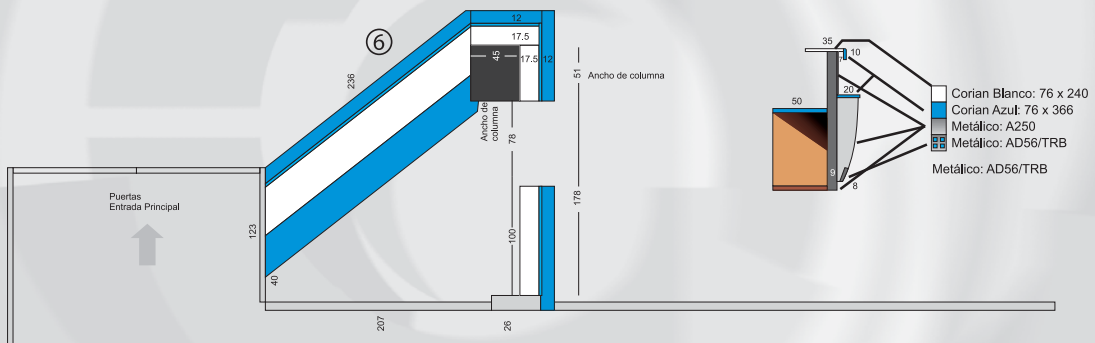
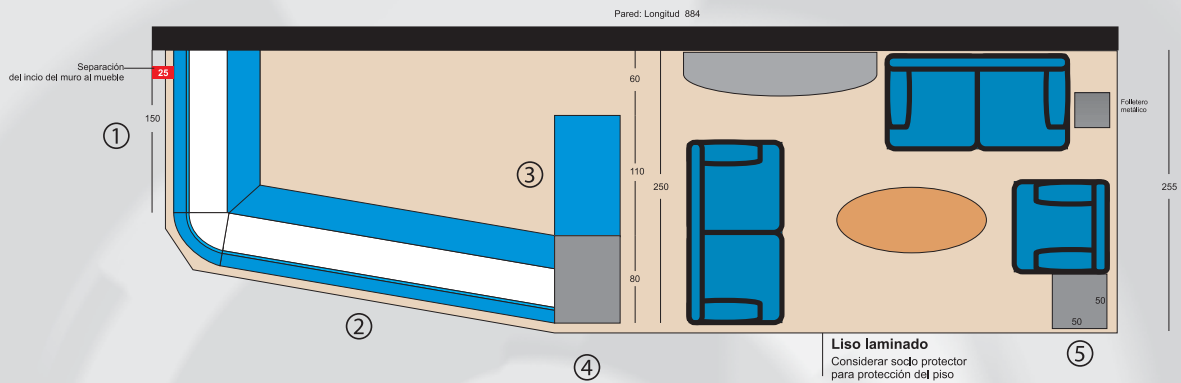
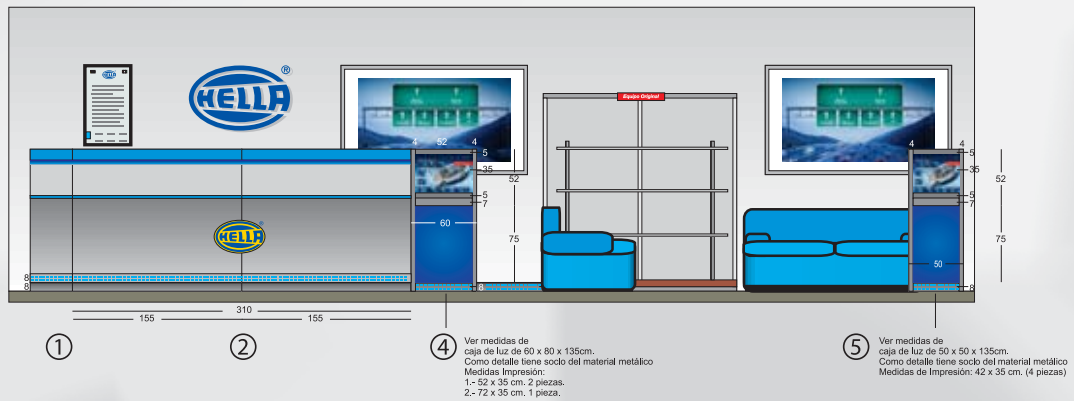

Distribución de espacios para el interior de los muebles de recepción

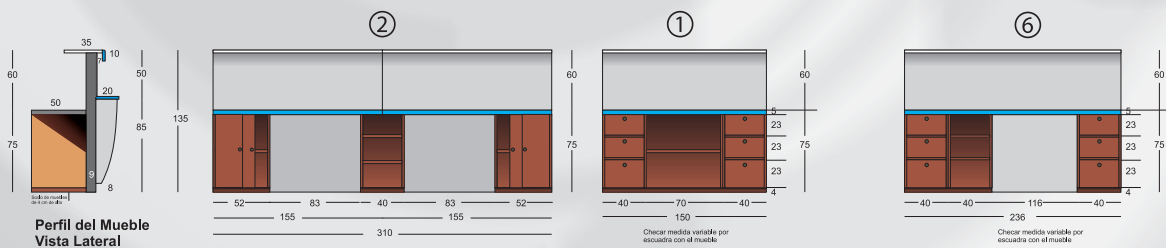

Perfil del Mueble  
Vista Lateral

Nota: Los acabados de los muebles de madera serán metálicos para hacer juego con el exterior.

Escala 1:10

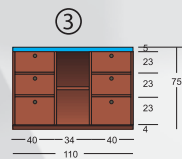

168

Hellamex, S.A. de C.V.

Reception Area

Furniture design and decoration

# 169

**HELLA Automotive South Africa (Pty) Ltd**  
 Worklamps display  
 Durabond material + Sintra  
 Full colour printed + plastic laminated  
 Holds 3-4 worklamps



**HELLA Automotive South Africa (Pty) Ltd**  
 Promotional printed material

# 170

**HELLA Automotive South Africa (Pty) Ltd**  
 Spotlights display  
 Durabond material + Sintra  
 Full colour printed + plastic laminated  
 Holds 5 spotlights





171

HELLA Automotive South Africa (Pty) Ltd  
4 x 4 Spotlights display  
Wood + Sintra (Header)  
Full colour printed + plastic laminated  
Holds 10 spotlights



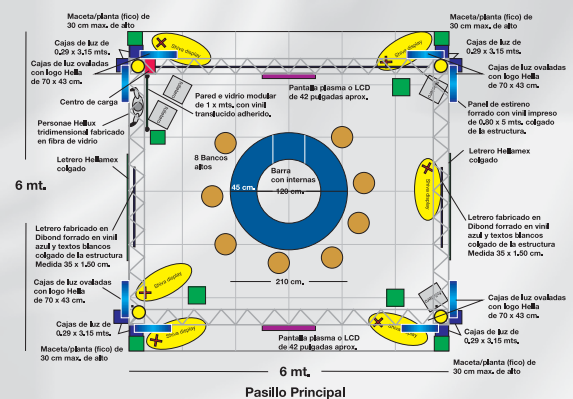

# 172

HELLAMEX S.A. de C.V.

Stand design for 2006-2010 (6 x 6 m, 8 x 12 m)

Wood (floor columns) + metallic structure + LCD screen  
Interactive kiosk + real life size figurine



173

HELLA Automotive South Africa (Pty)Ltd.

Mining display set

Full colour printed stand display



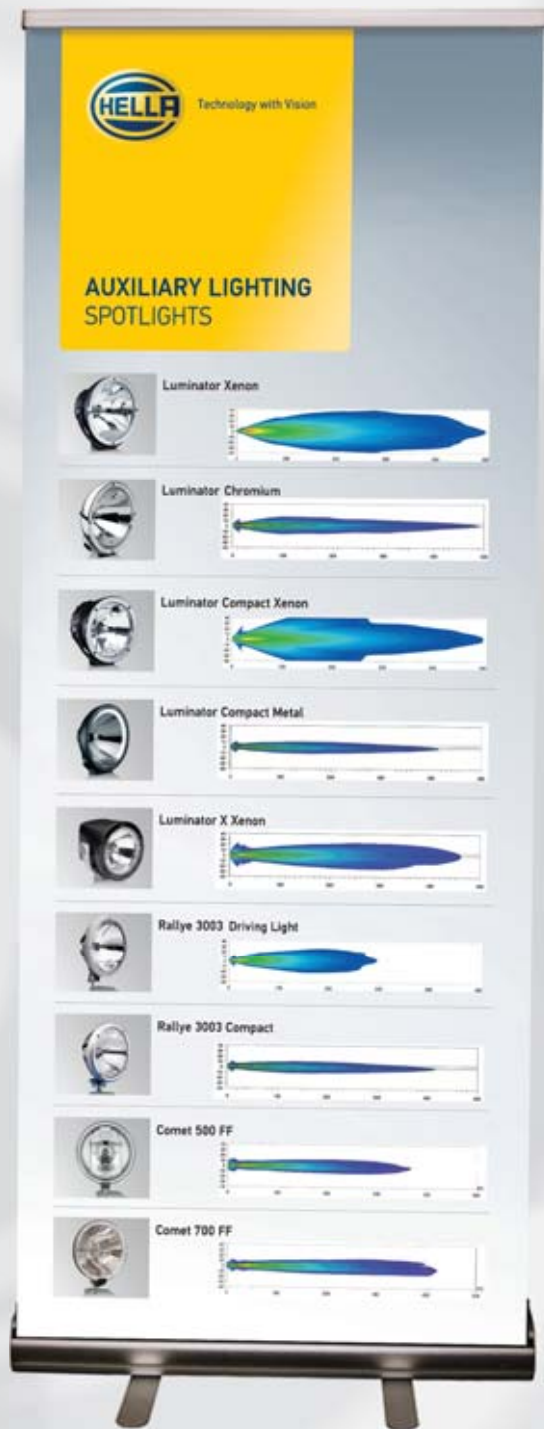

Exhibitions and POP Materials

174

HELLA Automotive South Africa (Pty)Ltd.  
Corporate display set  
Full colour printed stand display



### Vista Lateral

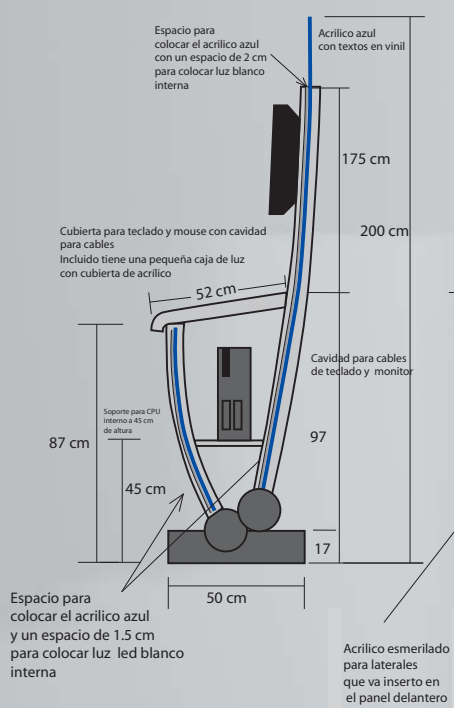

### Vista Frontal



175

HELLAMEX S.A. de C.V.  
 Information module (interactive kiosk)  
 Wood + LED lighting + Light box + CPU + LCD screen



176

HELLAMEX S.A. de C.V.  
Leaflet dispenser



177

HELLAMEX S.A. de C.V.  
Batteries display  
Sintra full colour printed (header)



178

HELLAMEX S.A. de C.V.  
Leaflet dispenser headers  
Perspex leaflet dispenser + card printed material

# 179

HELLA Automotive South Africa (Pty)Ltd.  
HELLA MINI Vehicle wrapping design  
CAD full colour printed



Logo on the back door must be 3D logo over yellow background with a width of 90 mm

2D Logo on the rear mirrors must be white with a width of 65 mm



Top: Real vehicle  
Next page: Design proposals + photographs

 SOUTH AFRICA  
| South Africa copy in white

HELLA Yellow is Pantone 116 C

Line art and white (minimum 1.8 mm)



85 mm (width) black stripes on back door with white outline of 1.8 mm



HELLA Racing Team

"HELLA Racing Team" must be white over black plastic





180

SKOLENI - Digital Art School  
Stand up display - set

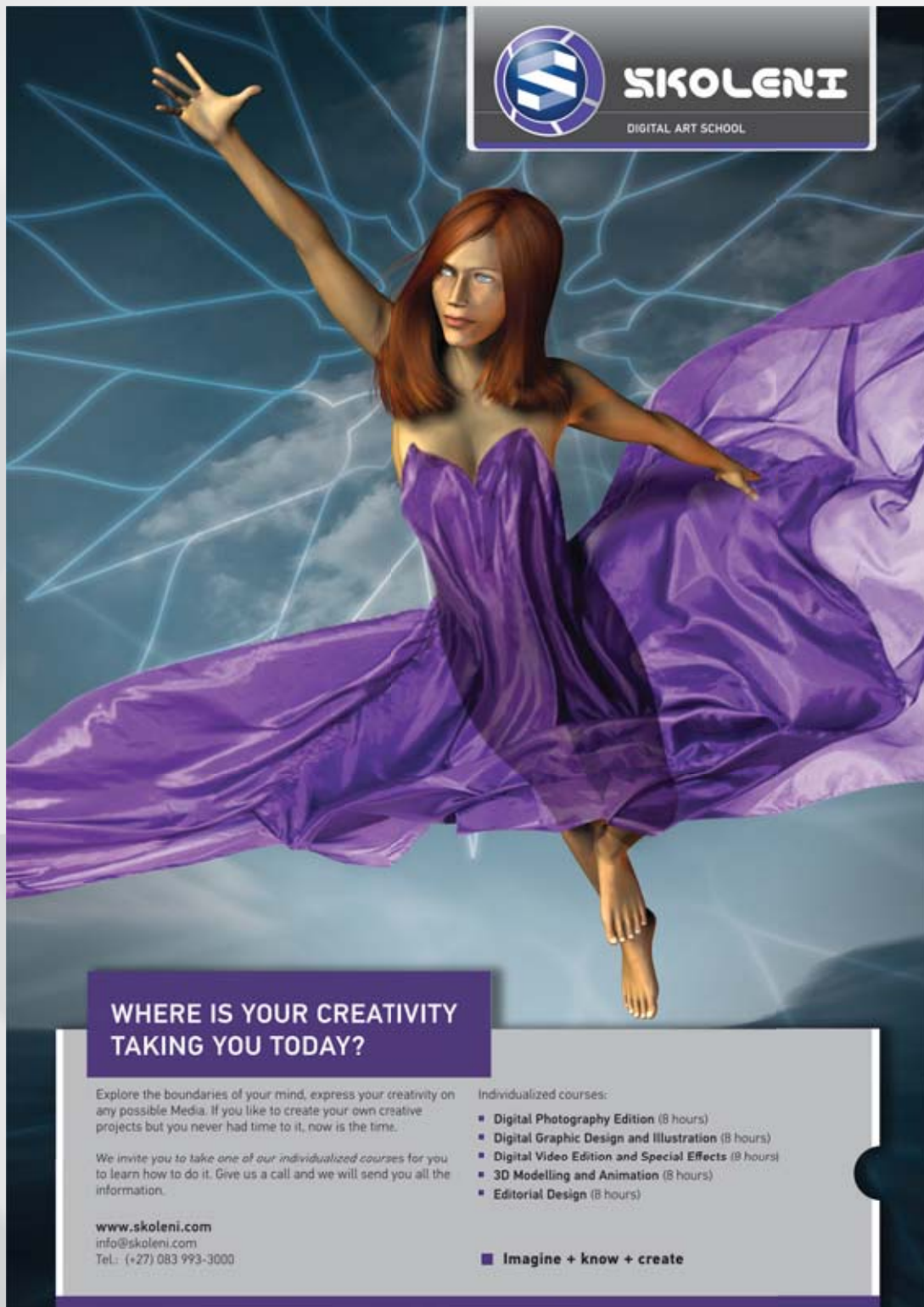

**WHERE IS YOUR CREATIVITY  
TAKING YOU TODAY?**

Explore the boundaries of your mind, express your creativity on any possible Media. If you like to create your own creative projects but you never had time to it, now is the time.

We invite you to take one of our individualized courses for you to learn how to do it. Give us a call and we will send you all the information.

[www.skoleni.com](http://www.skoleni.com)  
[info@skoleni.com](mailto:info@skoleni.com)  
 Tel: (+27) 083 993-3000

Individualized courses:

- Digital Photography Edition (8 hours)
- Digital Graphic Design and illustration (8 hours)
- Digital Video Edition and Special Effects (8 hours)
- 3D Modelling and Animation (8 hours)
- Editorial Design (8 hours)

■ **Imagine + know + create**

181

SKOLENI - Digital Art School  
 Poster + card dispenser  
 Board full colour printed





# Photography

Indoors / outdoors photography.

## A NEW POINT OF VIEW

182

Moscow, Russia, Tsarisino  
Park, 2012



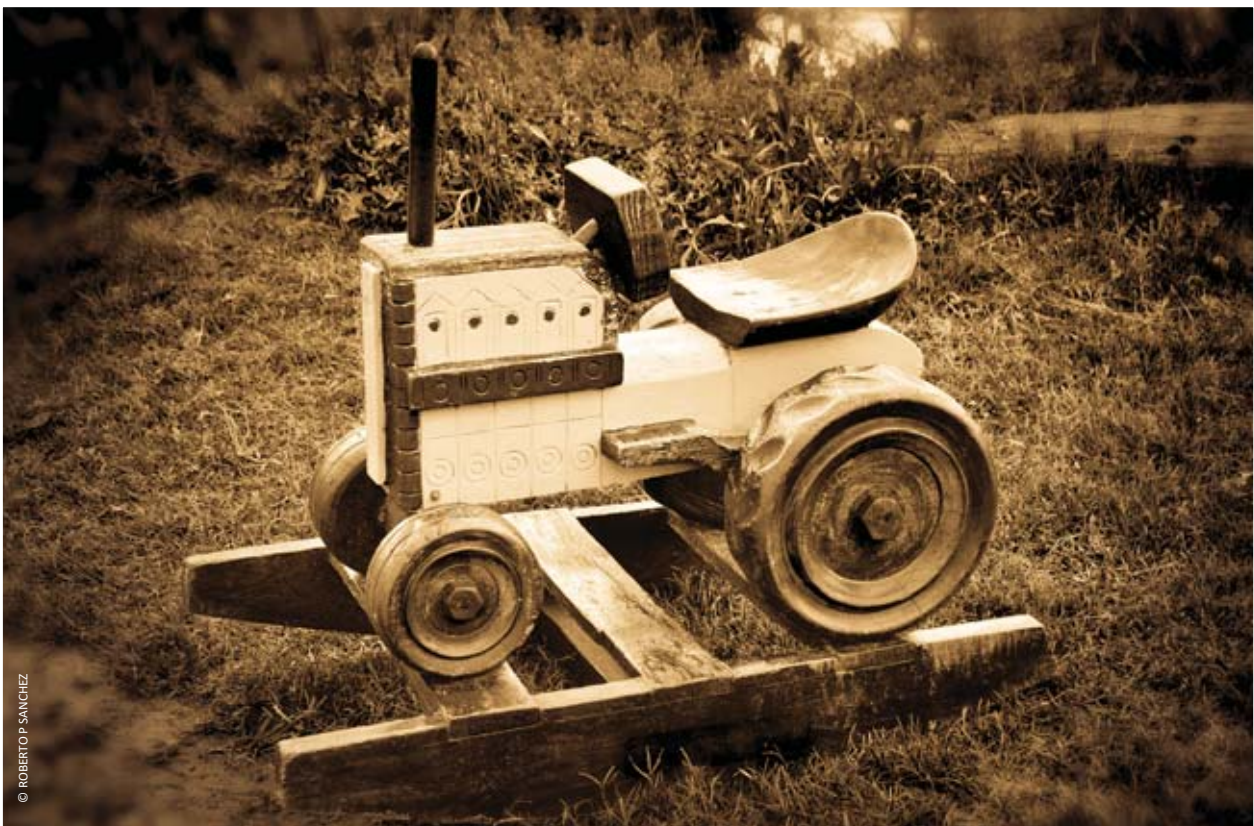

183

Kadmandu, Nepal  
2013

Right page (top)

184

Cuba, 50's composition  
2011

Right page (below)

185

South Africa, Kids  
playground, 2012





© ROBERTO P. SANCHEZ



© ROBERTO P. SANCHEZ

**186**  
In the eyes of Innocence, Mexico  
2012

Right page (top)  
**187**  
Amsterdam, Netherland  
2011

Right page (below)  
**188**  
Opera of Paris, France  
playground, 2008



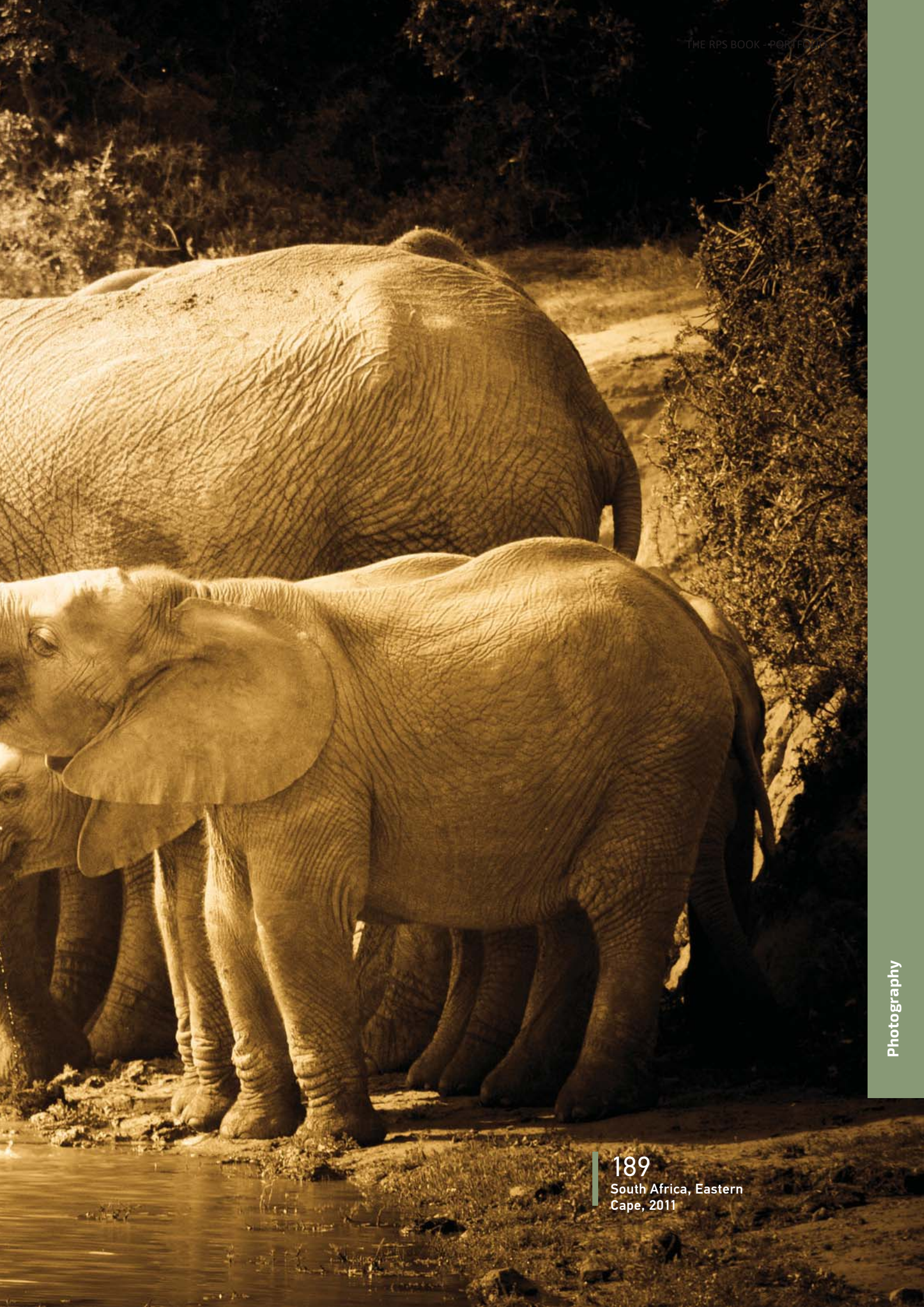







© ROBERTO P. SANCHEZ

190  
Kroger National Park,  
South Africa, 2014

191  
Jeffreys Bay, South  
Africa, 2013



© ROBERTO P. SANCHEZ



192

Cape Recife, South Africa,  
2014

193

Zurich, Switzerland,  
2012



© ROBERTO P. SANCHEZ

194

St. Petersburg, Rusia,  
Peterhoff, 2012

195

Athens, Greece,  
2012







© ROBERTO P. SANCHEZ



© ROBERTO P. SANCHEZ

Right page

**196**

Beijing, China  
2013

Left page (top)

**197**

Addo National Park  
South Africa, 2012

Left page (below)

**198**

Kroger National Park,  
South Africa, 2012







© ROBERTO P. SANCHEZ



© ROBERTO P. SANCHEZ

199  
Dresden, Germany,  
Landscape, 2012

Right page (top)  
200  
Bonn, Germany  
2012

Right page (below)  
201  
Berlin, Germany,  
2012



© ROBERTO P. SANCHEZ

202  
Vienna, Austria,  
2012

203  
Berlin, Germany,  
2012



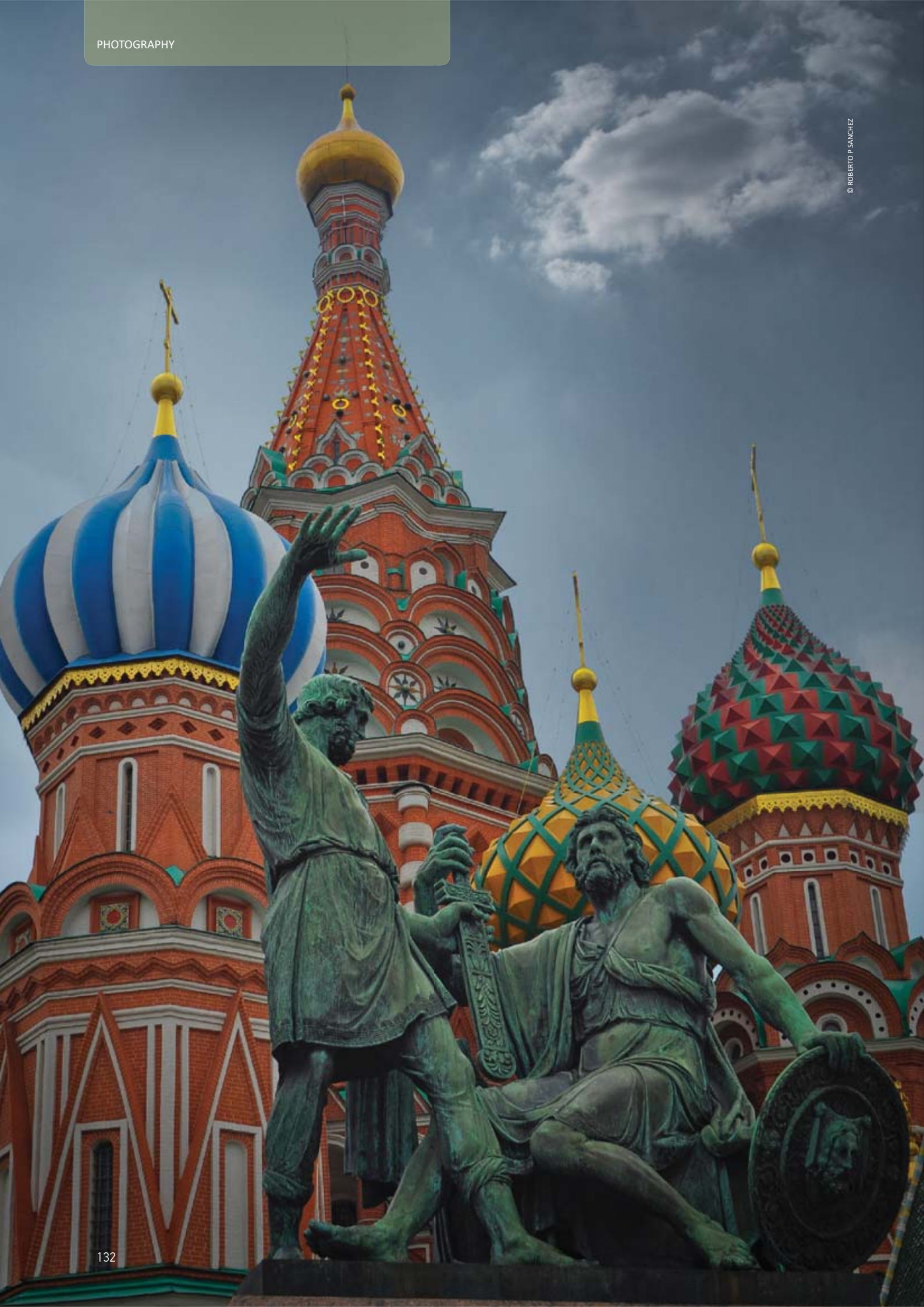



© ROBERTO P. SANCHEZ



© ROBERTO P. SANCHEZ

204

Moscow, Rusia, St. Basil's Cathedral, 2012

Right page (top)

205

Madrid, Spain, 2012

Right page (below)

206

Frankfurt, Germany, 2011



© ROBERTO P. SANCHEZ



Left page

207

Berlin, Germany  
2012

208

Brussels, Belgium  
2012







© ROBERTO P. SANCHEZ



© ROBERTO P. SANCHEZ

Left page (top)

**209**  
Paris, France,  
2008

Left page (below)

**210**  
Paris, France, Arc of  
Triumph, 2008

**211**  
Paris, France,  
2008



© ROBERTO P. SANCHEZ

212

Prague, Czech Republic  
2012

213

Venice, Italy  
2008





© ROBERTO P. SANCHEZ

214  
Venice, Italy  
2008

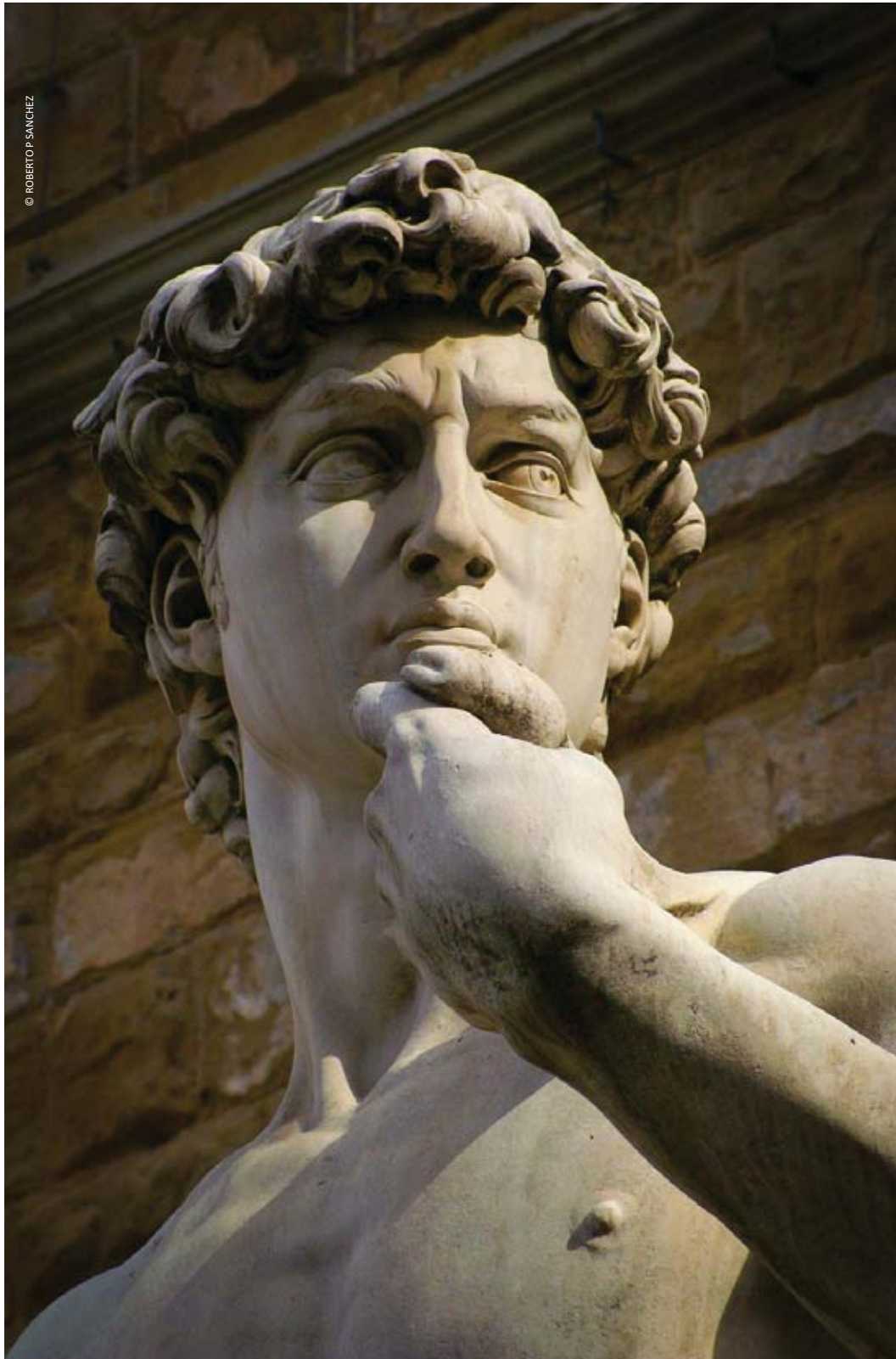

© ROBERTO P. SANCHEZ

215  
Florence, Italy  
2008



© ROBERTO P. SANCHEZ

Left page

**216**

South Africa, Eastern Cape  
2011

Right page

**217**

South Africa, Port  
Elizabeth, 2012









© ROBERTO P. SANCHEZ

218

Port Elizabeth, South Africa,  
2012

219

Zurich, Switzerland  
2011



© ROBERTO P. SANCHEZ



© ROBERTO P. SANCHEZ

Left page (top)

**220**  
South Africa,  
Freedom Shop, 2012

Left page (below)

**221**  
South Africa, P Cape St.  
Francis, 2012

**222**  
South Africa, Knysna,  
2012





© ROBERTO P. SANCHEZ



© ROBERTO P. SANCHEZ

(Top image)

**223**

Buenos Aires, Argentina  
2011

(Below image)

**224**

Cancun, Mexico  
2008

(Top image)

**225**

Cuernavaca, Mexico  
2009







© ROBERTO P. SANCHEZ

226

San Miguel de Allende, Mexico  
2009

227

El Tajin, Mexico,  
2010







228  
Lesotho  
2013

229  
Monkey Temple, Nepal  
2013



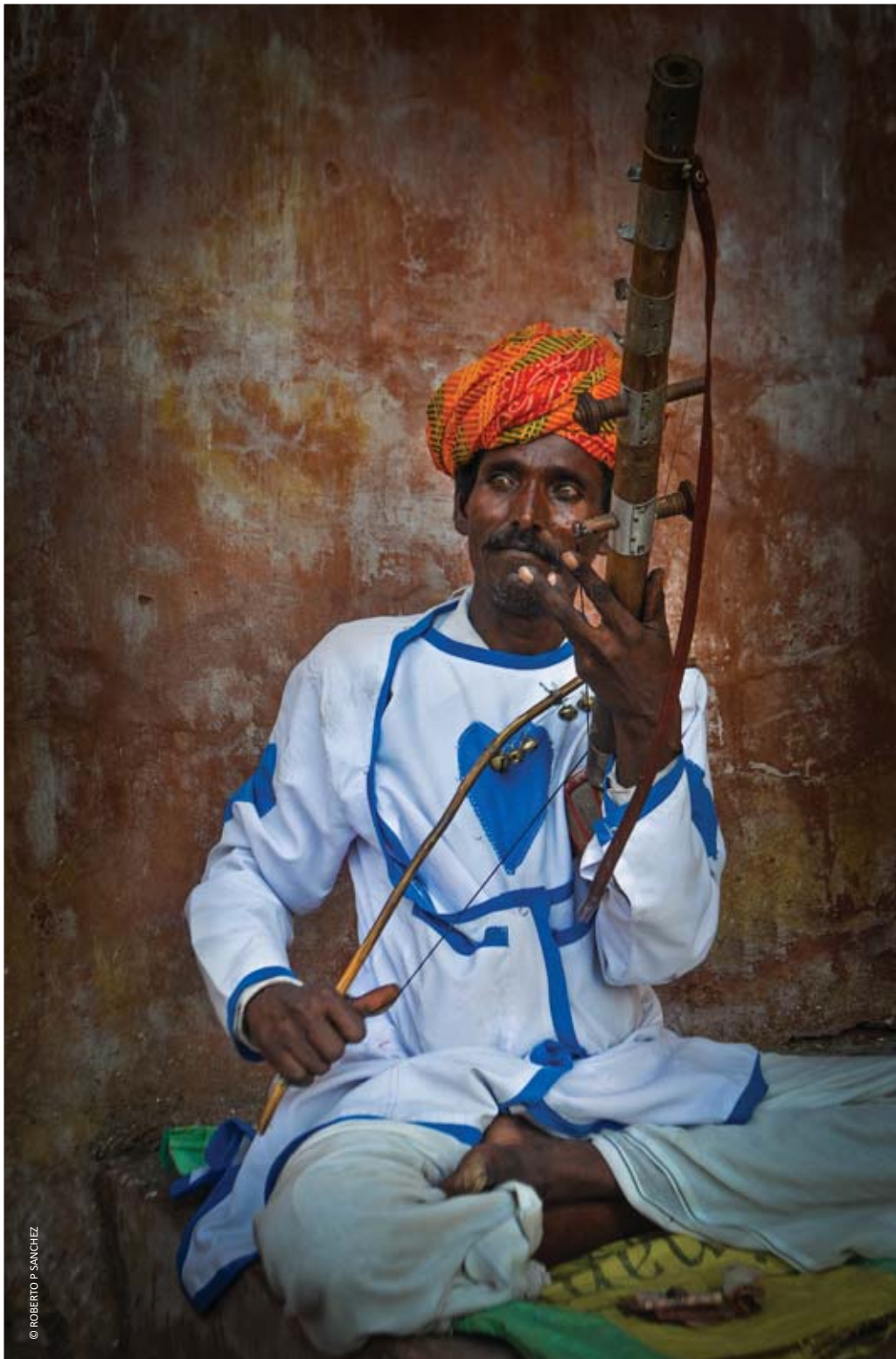

© ROBERTO P. SANCHEZ

230  
Katmandu, Nepal  
2013

231  
Jaipur, India  
2013

ID	DESCRIPTION	COMPANY NAME	CATEGORY	PAGE
001	Logotype and business stationery design	MAGIKA Studios - United States of America	Corporate Identity	12
002	Logotype and business stationery design	MDANGE Group - South Africa	Corporate Identity	14
003	Business stationery design.	TCW Studios	Corporate Identity	14
004	Logo design.	TCW Studios	Corporate Identity	15
005	Sales campaign material.	TCW Studios	Corporate Identity	15
006	Sales campaign material.	The Creative Workshop	Corporate Identity	16
007	Concept design for internal documents	The Creative Workshop	Corporate Identity	17
008	Concept design for storage devices	The Creative Workshop	Corporate Identity	17
009	Sleeve for interactive CD.	The Creative Workshop	Corporate Identity	17
010	Logo design	Claudiva Ledesma	Corporate Identity	18
011	Logo design	Napolis - Chocolate brand	Corporate Identity	18
012	Logo design	Max Cafe Group	Corporate Identity	18
013	Logo design	Mantecadas Pierre's	Corporate Identity	18
014	Logo design	Alterra - Music Store	Corporate Identity	18
015	Logo design	Arts Magazine	Corporate Identity	18
016	Logo design and business stationery	Skoleni - Digital Art School	Corporate Identity	19
017	Logo design, business stationery and corporate manual	Sweet Celeste	Corporate Identity	20
018	Logo design and business stationery	Unipack Group	Corporate Identity	21
019	Logo design	La Patisserie Francaise	Corporate Identity	22
020	Logo design, business stationery and corporate manual	Body Care Center	Corporate Identity	22
021	CD package including brochures and technical information.	Giftwrap - Packaging Services	Corporate Identity	23
022	Logo design, corporate identity manual, CD and stationery.	JJHF Ingeniería y Asociados	Corporate Identity	23
023	Logo and stationery business	Escuela Nacional de Directores Técnicos	Corporate Identity	24
024	Logo design (Basketball TV Show)	La Duella TV	Corporate Identity	25
025	Logo design - Traditional mexican restaurant	Taconmaiz	Corporate Identity	25
026	Sales Tool Kit. 40 pages. Full colour. Hard cover	The Creative Workshop	Corporate Identity	28
027	Brochure Corporate overview. 16 pages. CMYK + 1 Spot colour.	The Creative Workshop	Corporate Identity	29
028	Teotihuacan Leaflet, CMYK Printed. Paper: 150 g	Mr. Günther Willenbrock	Corporate Identity	30
029	Wiper blades catalogue. CMYK Paper: 150 g 8 pages.	BERU - Mexico	Corporate Identity	31
030	Postcard. CMYK Paper: 10 pts. Sulphated + UV coated	Skoleni - Digital School	Corporate Identity	32
031	New Mexican Photographers. 2 spot colours Paper: 150 g	Universidad Autonoma Metropolitana	Corporate Identity	32
032	Leaflet design. CMYK Paper: 10 pts. Sulphated + UV coated	HELLA Automotive South Africa (Pty) Ltd	Corporate Identity	33
033	High Performance Bulbs Poster CMYK Paper: 10 pts.	"HELLA Automotive South Africa (Pty) Ltd	Printed Literature	33
034	Catalogue - CMYK Paper: 150 g 12 pages.	Giftwrap - Packaging Services	Printed Literature	34
035	Catalogue - CMYK Paper: 150 g 12 pages.	Giftwrap - Packaging Services	Printed Literature	34
036	Catalogue - CMYK Paper: 150 g 60 pages.	HELLA Automotive South Africa (Pty) Ltd	Printed Literature	35
037	Catalogue - CMYK Paper: 150 g 6 pages.	PCE - Publicidad Corporativa Empresarial	Printed Literature	36
038	Taller 24 Horas, Magazine - CMYK Paper: 150 g. 56 pages.	Universidad Autonoma Metropolitana	Printed Literature	36
039	Poster - CMYK Printed. Paper: 150 g. Artwork + photos.	Hella Automotive Sales, Inc.	Printed Literature	37
040	Newsletter design - CMYK Printed. Artwork + Copy	Unipack Group	Printed Literature	38
041	Newsletter design - CMYK Printed. Artwork + Copy	SKOLENI - Digital School	Printed Literature	38
042	File folder design - CMYK Printed. Artwork + Copy	SKOLENI - Digital School	Printed Literature	38
043	Poster - CMYK Printed. Paper: 250 g Artwork + photos.	HELLA - Mexico Safety Tour	Printed Literature	39
044	Poster - CMYK Printed. Paper: 250 g Artwork + photos.	HELLA - Mexico. Hella Shop	Printed Literature	39
045	HELLA 4x4 Programme brochure	HELLA Automotive South Africa (Pty) Ltd	Printed Literature	40
046	HELLA Relays and Flashers brochure	HELLA Automotive South Africa (Pty) Ltd	Printed Literature	40
047	HELLA Lambda Sensors brochure	HELLA Automotive South Africa (Pty) Ltd	Printed Literature	40
048	HELLA Bulbs Brochure	HELLA Automotive South Africa (Pty) Ltd	Printed Literature	40
049	HELLA Wiperblades brochure	HELLA Automotive South Africa (Pty) Ltd	Printed Literature	40
050	HELLA Thermostats brochure	HELLA Automotive South Africa (Pty) Ltd	Printed Literature	40
051	HELLA Worklights leaflet	HELLA Automotive South Africa (Pty) Ltd	Printed Literature	40
052	HELLA Power Beam 5000 Leaflet	HELLA Automotive South Africa (Pty) Ltd	Printed Literature	40
053	HELLA Spotlights leaflet	HELLA Automotive South Africa (Pty) Ltd	Printed Literature	40
054	HELLA High performance bulbs leaflet	HELLA Automotive South Africa (Pty) Ltd	Printed Literature	41
055	HELLA Concepts Displays leaflet	HELLA Automotive South Africa (Pty) Ltd	Printed Literature	41
056	HELLA Horns leaflet	HELLA Automotive South Africa (Pty) Ltd	Printed Literature	41
057	HELLA Luminator X Halogen leaflet	HELLA Automotive South Africa (Pty) Ltd	Printed Literature	41
058	HELLA New Packaging leaflet	HELLA Automotive South Africa (Pty) Ltd	Printed Literature	41
059	HELLA Rallye FF leaflet	HELLA Automotive South Africa (Pty) Ltd	Printed Literature	41

ID	DESCRIPTION	COMPANY NAME	CATEGORY	PAGE
060	HELLA Taxi Horns leaflet	HELLA Automotive South Africa (Pty) Ltd	Printed Literature	41
061	HELLA 4 x4 display leaflet	HELLA Automotive South Africa (Pty) Ltd	Printed Literature	41
062	HELLA Advertisement	HELLA Automotive South Africa (Pty) Ltd	Printed Literature	41
063	HELLA Batteries brochure	Hellamex, S. A. de C.V.	Printed Literature	42
064	HELLA Bulbs Brochure	Hellamex, S. A. de C.V.	Printed Literature	42
065	HELLA Electrics / Electronics brochure	Hellamex, S. A. de C.V.	Printed Literature	42
066	HELLA Diagnostic Tools	Hellamex, S. A. de C.V.	Printed Literature	42
067	HELLA Wiperblades brochure	Hellamex, S. A. de C.V.	Printed Literature	42
068	HELLA Bulbs Brochure	Hellamex, S. A. de C.V.	Printed Literature	42
069	HELLA Bulbs blister pack	Hellamex, S. A. de C.V.	Printed Literature	42
070	HELLA Electronics brochure	Hellamex, S. A. de C.V.	Printed Literature	42
071	HELLA Products for SEAT	Hellamex, S. A. de C.V.	Printed Literature	42
072	HELLA Spark plug cables	Hellamex, S. A. de C.V.	Printed Literature	43
073	HELLA Automotive lighting products	Hellamex, S. A. de C.V.	Printed Literature	43
074	HELLA Wiperblades brochure	Hellamex, S. A. de C.V.	Printed Literature	43
075	HELLA Promotional material brochure	Hellamex, S. A. de C.V.	Printed Literature	43
076	HELLA Automotive lighting products brochure	Hellamex, S. A. de C.V.	Printed Literature	43
077	BEHR HELLA Service brochure	Hellamex, S. A. de C.V.	Printed Literature	43
078	HELLA Tools Brochure	Hellamex, S. A. de C.V.	Printed Literature	43
079	HELLA Electronics brochure	Hellamex, S. A. de C.V.	Printed Literature	43
080	HELLA Fuel Pumps and ignition modules	Hellamex, S. A. de C.V.	Printed Literature	44
081	HELLA New products brochure	Hellamex, S. A. de C.V.	Printed Literature	44
082	HELLA Products for Peugeot brochure	Hellamex, S. A. de C.V.	Printed Literature	44
083	HELLA Products for VW Golf / Jetta brochure	Hellamex, S. A. de C.V.	Printed Literature	44
084	HELLA Products for VW Pointer brochure	Hellamex, S. A. de C.V.	Printed Literature	44
085	HELLA Products for GM Chevy brochure	Hellamex, S. A. de C.V.	Printed Literature	44
086	HELLA New products for trucks brochure	Hellamex, S. A. de C.V.	Printed Literature	44
087	HELLA Trucks wiperblades	Hellamex, S. A. de C.V.	Printed Literature	44
088	HELLA Coolant range leaflet	Hellamex, S. A. de C.V.	Printed Literature	45
089	HELLA Batteries leaflet	Hellamex, S. A. de C.V.	Printed Literature	45
090	HELLA Relays leaflet	Hellamex, S. A. de C.V.	Printed Literature	45
091	HELLA Bus products leaflet	Hellamex, S. A. de C.V.	Printed Literature	45
092	HELLA Flasher leaflet	Hellamex, S. A. de C.V.	Printed Literature	45
093	HELLA Lambda sensors leaflet	Hellamex, S. A. de C.V.	Printed Literature	45
094	HELLA Temperature sensors leaflet	Hellamex, S. A. de C.V.	Printed Literature	45
095	HELLA Newsletter - Feb 2008	Hellamex, S. A. de C.V.	Printed Literature	46
096	HELLA Newsletter - Mar 2008	Hellamex, S. A. de C.V.	Printed Literature	46
097	HELLA Newsletter - Dec 2007	Hellamex, S. A. de C.V.	Printed Literature	46
098	HELLA Newsletter - Ago 2005	Hellamex, S. A. de C.V.	Printed Literature	46
099	HELLA Newsletter - Ago 2007	Hellamex, S. A. de C.V.	Printed Literature	46
100	HELLA Newsletter - Oct 2005	Hellamex, S. A. de C.V.	Printed Literature	46
101	HELLA Newsletter - Dec 2006	Hellamex, S. A. de C.V.	Printed Literature	46
102	HELLA Newsletter - Nov 2006	Hellamex, S. A. de C.V.	Printed Literature	46
103	HELLA Newsletter - Feb 2006	Hellamex, S. A. de C.V.	Printed Literature	46
104	HELLA Newsletter - Jan 2007	Hellamex, S. A. de C.V.	Printed Literature	46
105	HELLA Advertisement Electrics	Hellamex, S. A. de C.V.	Printed Literature	47
106	HELLA Advertisement Wiperblades	Hellamex, S. A. de C.V.	Printed Literature	47
107	HELLA Advertisement Spotlights	Hellamex, S. A. de C.V.	Printed Literature	47
108	HELLA Advertisement Batteries	Hellamex, S. A. de C.V.	Printed Literature	47
109	HELLA Advertisement Electronics	Hellamex, S. A. de C.V.	Printed Literature	47
110	HELLA Advertisement Electrics	Hellamex, S. A. de C.V.	Printed Literature	47
111	HELLA Advertisement Lighting	Hellamex, S. A. de C.V.	Printed Literature	47
112	HELLA Advertisement Competition	Hellamex, S. A. de C.V.	Printed Literature	47
113	Festive seasons card, CMYK - Also electronically distributed	Hellamex, S. A. de C.V.	Printed Literature	48
114	Festive seasons card, CMYK - Also electronically distributed	Hellamex, S. A. de C.V.	Printed Literature	48
115	HELLA Advertisement Letter size - lighting	Hellamex, S. A. de C.V.	Printed Literature	49
116	HELLA Advertisement Letter size - coolant	Hellamex, S. A. de C.V.	Printed Literature	49
117	HELLA Advertisement Letter size - wiper blades	Hellamex, S. A. de C.V.	Printed Literature	49
118	HELLA Advertisement Letter size - headlights	Hellamex, S. A. de C.V.	Printed Literature	49

ID	DESCRIPTION	COMPANY NAME	CATEGORY	PAGE
119	HELLA Advertisement Letter size - Product range	Hellamex, S. A. de C.V.	Printed Literature	49
120	HELLA Advertisement Letter size - Product range	Hellamex, S. A. de C.V.	Printed Literature	49
121	HELLA Advertisement Letter size - Special OE	Hellamex, S. A. de C.V.	Printed Literature	49
122	HELLA Advertisement Letter size - Truck range	Hellamex, S. A. de C.V.	Printed Literature	49
123	Labels design, 5 L and 946 ml packages CYMK + metallic foil	Hella Sintetic Oil - Anti Freeze/Coolant	Packaging	52
124	Artwork design and packaging concept, CYMK	Hella Valuefit Lighting Accessories	Packaging	53
125	Artwork+ packaging. Printed CMYK + UV varnish.	Hellamex, S. A. de C.V. Antifreeze	Packaging	54
126	Artwork design and packaging concept, CYMK + cardboard.	Hella Bulbs Halogen and Miniature	Packaging	54
127	Artwork design and packaging concept, CYMK	Hella Wiper Blades Standard (USA)	Packaging	55
128	Packaging design, CYMK + metallic foil + UV varnish	Hella Hight Performance Bulbs (USA)	Packaging	55
129	Artwork design and packaging concept, CYMK	Hella Spark Plug Cables	Packaging	56
130	Artwork design and packaging concept, CYMK	HELLA Automotive South Africa (Pty) Ltd	Packaging	56
131	Artwork design and packaging concept, CYMK + metallic foil	Wiper Blades - Hellamex, S. A. de C.V.	Packaging	57
132	Artwork design and packaging concept, CYMK + metallic foil	Pierres - La Patiserie Francaise.	Packaging	58
133	Illustration + Artwork design and packaging concept, CYMK	Napolis- Milky Chocolate	Packaging	58
134	Artwork design and packaging concept, CYMK + cardboard.	Tacon Maiz	Packaging	59
135	Artwork design and packaging, CYMK + cardboard.	Papinni - Fried chips	Packaging	59
136	Artwork design and packaging, CYMK + cardboard.	Hella Automotive Sales Inc. Blister bulbs	Packaging	60
137	Automotive bulbs packaging - More than 60 different models	BERU AG.	Packaging	61
138	Starter and Alternator packaging concept, CYMK	Hellamex, S. A. de C.V.	Packaging	62
139	Hella horns and trumpets packaging concept, CYMK	HELLA Automotive South Africa (Pty) Ltd	Packaging	62
140	Hella Automotive set - label design	Hellamex, S. A. de C.V.	Packaging	63
141	Spotlights packaging - More than 11 different models	Hella USA, South Africa, Germany	Packaging	63
142	Label design for HELLA batteries	Hella Automotive Sales Inc. Blister bulbs	Packaging	64
143	Bags and promotional material	Alterra Music Store	Packaging	65
144	Packaging concept, label design CYMK, Metallic foil	Hella Automotive Sales Inc. Emergency set	Packaging	65
145	Web site design (HTML / Flash) - Concept, RGB	Giftwrap - Packaging Services	Web Sites	68
146	Web site design (HTML / Flash) - Concept, RGB	ENDIT - National Soccer Managers School	Web Sites	69
147	Web site design (HTML / Flash) - Concept, RGB	JJHF - Ingenieria y Asociados	Web Sites	70
148	Web site design (HTML / Flash) - Concept, RGB	Violeta Medrano - Jewelry Designer	Web Sites	71
149	Web site design (HTML / Flash) - Concept, RGB	Qualcomm - Omnitracs	Web Sites	72
150	Internet banner Flash- RGB	Volvo Trucks	Web Sites	73
151	Web site design (HTML / Flash) - Concept, RGB	The Creative Workshop	Web Sites	73
152	Interactive CD (Flash + Video + 3D), RGB	Hellamex, S. A. de C.V.	Video and Interactive	76
153	Interactive CD (Flash + Video + 3D), RGB	Rafael del Moral - ENDIT	Video and Interactive	78
154	ADN-F Interactive CD (Flash + Video), RGB	Almacenamiento y Distribución Nacional S.A. de C.V.	Video and Interactive	80
155	Interactive CD (Flash + Video + 3D), RGB	Asociación Mexicana de Proveedores de	Video and Interactive	81
156	Becel de Capullo, Interactive CD (Flash + 3D), RGB	UNILEVER de Mexico, S.A. de CV.	Video and Interactive	82
157	Knax de Knorr, Interactive CD (Flash + 3D), RGB	UNILEVER de Mexico, S.A. de CV.	Video and Interactive	83
158	Safetyman, Interactive CD (Flash + Powepoint + 3D), RGB	UNILEVER de Mexico, S.A. de CV.	Video and Interactive	84
159	Azitrocin, Interactive CD (Flash - Apps), RGB	Pfizer	Video and Interactive	86
160	Dalacin, Interactive CD (Flash - Apps), RGB	Pfizer	Video and Interactive	87
161	Interactive CD (Flash + Video + 3D), RGB	JJHF - Ingenieria y Asociados	Video and Interactive	88
162	FF-150 interactive CD (Flash - Apps), RGB	HELLA Inc. (USA) -	Video and Interactive	89
163	High Performance Bubs, Flash animation banners, RGB	HELLA Automotive South Africa (Pty) Ltd	Video and Interactive	90
164	Sales Company of the Year, Interactive (Flash + 3D), RGB	Hellamex, S. A. de C.V.	Video and Interactive	91
165	Video (3D - FX), Broadcast, RGB	La Duela TV - TV sport show	Video and Interactive	92
166	Hella Pagid - High Carbon Brake Rotors (3D), RGB	Hella, Inc. (USA)	Video and Interactive	94
167	Hella High Performance bulbs 2.0 (3D), RGB	Hella, Inc. (USA)	Video and Interactive	95
168	Reception Area, furniture design and decoration	Hellamex, S. A. de C.V.	Exhibitions and POP	98
169	Worklamps display, Durabond material + Sintra,	HELLA Automotive South Africa (Pty) Ltd	Exhibitions and POP	100
170	Spotlights display, Durabond material + Sintra	HELLA Automotive South Africa (Pty) Ltd-	Exhibitions and POP	100
171	4 x 4 Spotlights display, Wood + Sintra (Header)	HELLA Automotive South Africa (Pty) Ltd	Exhibitions and POP	101
172	Stand design for FY 2006-2010	Hellamex, S. A. de C.V.	Exhibitions and POP	102
173	Mining display set, full colour printed stand up display	HELLA Automotive South Africa (Pty) Ltd	Exhibitions and POP	104
174	Corporate display set, full colour printed stand up display	HELLA Automotive South Africa (Pty) Ltd	Exhibitions and POP	105
175	Information module (interactive kiosk), wood + LED lighting	Hellamex, S. A. de C.V.	Exhibitions and POP	106
176	Leaflet dispenser	Hellamex, S. A. de C.V.	Exhibitions and POP	107
177	Batteries display, Sintra full colour printed (header)	Hellamex, S. A. de C.V.	Exhibitions and POP	107

ID	DESCRIPTION	COMPANY NAME	CATEGORY	PAGE
178	Leaflet dispenser headers, Perspex leaflet dispenser + card	Hellamex, S. A. de C.V.	Exhibitions and POP	107
179	HELLA MINI Vehicle wrapping design, CAD vinyl full colour	HELLA Automotive South Africa (Pty) Ltd	Exhibitions and POP	108
180	Stand up display - set	SKOLENI - Digital Art School	Exhibitions and POP	110
181	Poster + card dispenser, board full colour printed	SKOLENI - Digital Art School	Exhibitions and POP	111
182	Moscow, Russia, Tsarino Park, 2012	Roberto Sanchez	Photography	112
183	Kadmandu, Nepal	Roberto Sanchez	Photography	114
184	Cuba, 50's composition, 2011	Roberto Sanchez	Photography	115
185	South Africa, Kids playground, 2012	Roberto Sanchez	Photography	115
186	In the eyes of innocence, Mexico City, 2012	Roberto Sanchez	Photography	116
187	Amsterdam, Netherlands, Street, 2011	Roberto Sanchez	Photography	117
188	Paris, France, Opera House, 2008	Roberto Sanchez	Photography	117
189	South Africa, Eastern Cape	Roberto Sanchez	Photography	118
190	Kroger National Park	Roberto Sanchez	Photography	120
191	Jeffreys Bay, South Africa, Lighthouse, 2012	Roberto Sanchez	Photography	121
192	Cape Recife, South Africa, Lighthouse	Roberto Sanchez	Photography	122
193	Zurich, Switzerland, 2012	Roberto Sanchez	Photography	123
194	St. Petersburg, Russia, Peterhoff, 2012	Roberto Sanchez	Photography	124
195	Athens, Greece, 2012	Roberto Sanchez	Photography	125
196	Beijing, Forbidden City, 2013	Roberto Sanchez	Photography	126
197	Addo National Park, South Africa, 2012	Roberto Sanchez	Photography	127
198	Kroger National Park, South Africa, 2012	Roberto Sanchez	Photography	127
199	Dresden, Germany, Landscape, 2012	Roberto Sanchez	Photography	128
200	Bonn, Germany, 2012	Roberto Sanchez	Photography	129
201	Berlin, Germany, 2012	Roberto Sanchez	Photography	129
202	Vienna, Austria, 2012	Roberto Sanchez	Photography	130
203	Berlin, Germany, 2012	Roberto Sanchez	Photography	131
204	Moscow, Russia, St. Basil's Cathedral, 2012	Roberto Sanchez	Photography	132
205	Madrid, Spain, 2012	Roberto Sanchez	Photography	133
206	Frankfurt, Germany, 2011	Roberto Sanchez	Photography	133
207	Berlin, Germany, 2012	Roberto Sanchez	Photography	134
208	Brussels, Belgium, 2012	Roberto Sanchez	Photography	135
209	Paris, France, 2008	Roberto Sanchez	Photography	136
210	Paris, France, Arc of Triumph, 2008	Roberto Sanchez	Photography	137
211	Paris, France, 2008	Roberto Sanchez	Photography	137
212	Czech Republic, Landscape, 2012	Roberto Sanchez	Photography	138
213	Venice, Italy, 2008	Roberto Sanchez	Photography	139
214	Venice, Italy, 2008	Roberto Sanchez	Photography	140
215	Florence, Italy, 2008	Roberto Sanchez	Photography	141
216	South Africa, Eastern Cape, 2011	Roberto Sanchez	Photography	142
217	Port Elizabeth, South Africa, 2012	Roberto Sanchez	Photography	143
218	Port Elizabeth, South Africa, 2012	Roberto Sanchez	Photography	144
219	Zurich, Switzerland, 2011	Roberto Sanchez	Photography	145
220	South Africa, Freedom Shop, 2012	Roberto Sanchez	Photography	146
221	South Africa, Cape St. Francis, 2012	Roberto Sanchez	Photography	146
222	South Africa, Knysna, 2012	Roberto Sanchez	Photography	147
223	Buenos Aires, Argentina, 2011	Roberto Sanchez	Photography	148
224	Cancun, Mexico, 2008	Roberto Sanchez	Photography	148
225	Cuernavaca, Mexico, 2009	Roberto Sanchez	Photography	149
226	San Miguel de Allende, Mexico, 2009	Roberto Sanchez	Photography	150
227	El Tajin, Mexico, 2010	Roberto Sanchez	Photography	151
228	Lesotho	Roberto Sanchez	Photography	152
229	Monkey Temple, Nepal, 2013	Roberto Sanchez	Photography	153
230	Katmandu, Nepal	Roberto Sanchez	Photography	154
231	Jaipur, India	Roberto Sanchez	Photography	155

ID	DESCRIPTION	COMPANY NAME	CATEGORY	PAGE
237	The waiting, Kadmandu, Nepal	Roberto Sanchez	Photography	154
238	San Miguel de Allende, Mexico, 2010	Roberto Sanchez	Photography	155

## PORTFOLIO STATISTICS

CATEGORY	NUMBER OF PROJECTS
Corporate Identity	32
Printed Literature	98
Packaging	19
Web Sites	7
Video and Interactive	14
Exhibitions and POP Materials	14
Photography	52
<b>Totals</b>	<b>236</b>

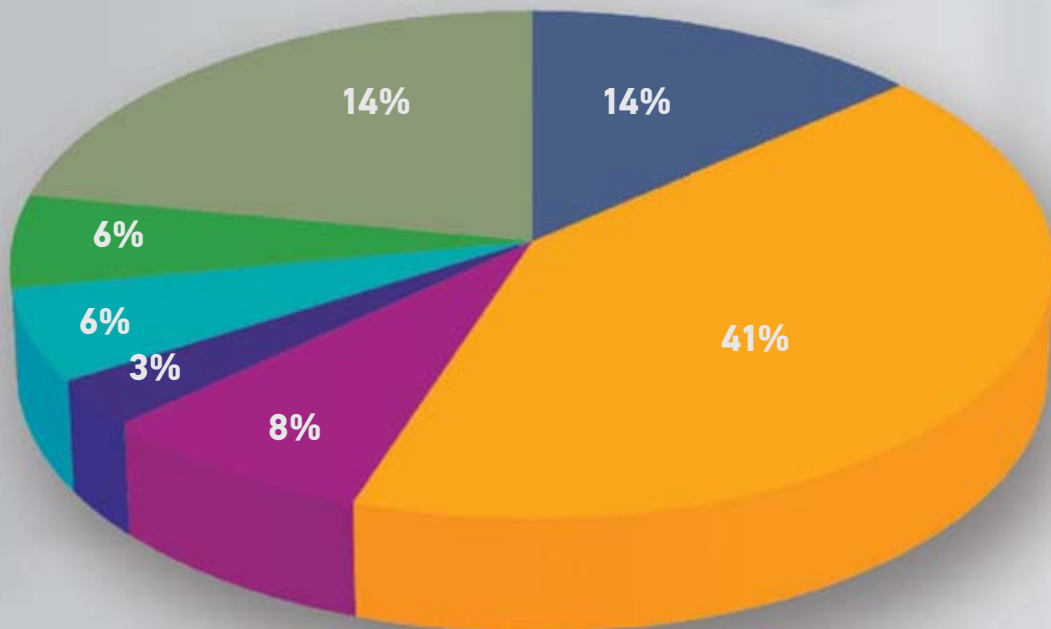



## ADDITIONAL INFORMATION

---

Additional information such as professional experience facts, personal information and training and others, it can be found on the following link.

<https://www.linkedin.com/in/roberto-pablo-sanchez-a7876034>

Or simply scan the QR code shown below from your smartphone or tablet.

For the digital edition, simply click on the QR code below.



## PORTFOLIO INFORMATION

---

This portfolio has been entirely designed by Roberto Pablo Sanchez Segura, in South Africa and United States of America.

The type fonts used are HELLA DIN Universal, Calibri was designed by Lucas de Groot and Trajan Pro, designed by Carol Twombly.

The printing and binding is by Grand Prix Printers (Pty) Ltd, Port Elizabeth, South Africa for the printed edition, 2018

© RPS Portfolio - Second digital edition, August, 2018

Created with:  
Adobe InDesign CC  
Adobe Illustrator CC  
Adobe Photoshop CC  
Adobe Lightroom



## PORTFOLIO VIDEOS AND INTERACTIVE SAMPLES INCLUDED ON THE DVD DISC

### INSTRUCTIONS

---

#### STARTING THE CD:

In most machines, the CD program will start by itself simply after the CD is loaded into the CD-ROM of the machine. Alternatively, the CD may be started manually by left clicking on Start, then left clicking on My Computer and under Devices w/ Removable storage left click on RPS\_PortfolioDVD. If this still does not run the CD try right clicking on RPS\_PortfolioDVD and select open. This will allow you to view the files on the CD. Now left click on the explorer icon which is named RPS\_PortfolioDVD.html

Please feel free to contact me if you have any questions about how to run or operate your CD.

**[robertopablo.sanchez@gmail.com](mailto:robertopablo.sanchez@gmail.com)**

### CONTACT INFORMATION

---

#### Social Media:



[www.rpsportfolio.com](http://www.rpsportfolio.com)



[robertopablo.sanchez@gmail.com](mailto:robertopablo.sanchez@gmail.com)



[robertopablo.sanchez](https://www.linkedin.com/in/robertopablo.sanchez)



<https://www.facebook.com/robertopablo.sanchez1>



<https://www.linkedin.com/in/roberto-pablo-sanchez-a7876034>



<https://www.behance.net/robertopabddbd>



<https://twitter.com/RobertoPablo79>



[https://www.instagram.com/robertopablo\\_sanchez79/](https://www.instagram.com/robertopablo_sanchez79/)



## THE RPS BOOK - PORTFOLIO

**EDITOR / AUTHOR:**  
**ROBERTO P. SANCHEZ**

Queda rigurosamente prohibido sin autorización escrita del editor bajo las sanciones establecidas en las leyes, la reproducción parcial o total de esta obra por cualquier medio o procedimiento, comprendidos la reprografía y el tratamiento informático y la distribución de ejemplares de ella, mediante alquiler o préstamo público.

Its expressly prohibited from reproducing, distributing, transforming, publicly communicating, making available to others, extracting, re-using, forwarding or exploiting, by any means or procedure, the content of this publication and its components, except where permitted by law or with the express written authorisation of the author.